



INSTALLATION AND OPERATION MANUAL

Desiccant dryer
Condair DA 65

Thank you for choosing Condair

Installation date (MM/DD/YYYY):

Commissioning date (MM/DD/YYYY):

Site:

Model:

Serial number:

Proprietary Notice

This document and the information disclosed herein are proprietary data of Condair Group AG. Neither this document, nor the information contained herein shall be reproduced, used, or disclosed to others without the written authorisation of Condair Group AG, except to the extent required for installation or maintenance of recipient's equipment.

Liability Notice

Condair Group AG does not accept any liability due to incorrect installation or operation of the equipment or due to the use of parts/components/equipment that are not authorised by Condair Group AG.

Copyright Notice

© Condair Group AG, All rights reserved.

Technical modifications reserved.

CONTENTS

SECTION 1 / GENERAL BACKGROUND	4
ABOUT THIS HANDBOOK	4
ABOUT MANAGING HUMIDITY	6
ABOUT CONDAIR	7
SECTION 2 / THE DEHUMIDIFIER	8
ABOUT THE CONDAIR DA 65E/DA 65D/DA 65C RANGE OF DEHUMIDIFIERS	8
HOW IT WORKS	12
FEATURES AND BENEFITS	16
SECTION 3 / TECHNICAL DETAILS	18
SERIAL NUMBER/IDENTIFICATION	18
SPECIFICATIONS	19
ASSEMBLIES AND COMPONENTS	26
SOUND LEVELS	31
SECTION 4 / INSTALLATION	32
HOW TO INSTALL THIS DEHUMIDIFIER	32
HOW TO INSTALL A CONDENSATION UNIT OR HEAT RECOVERY UNIT	36
HOW TO INSTALL A DA 65C (COLD STORE MODEL)	39
HOW TO COMMISSION THIS DEHUMIDIFIER	42
SECTION 5 / OPERATION	44
HOW TO OPERATE THIS DEHUMIDIFIER	44
HOW TO OPERATE THE DA 65E / DA 65D CONFIGURATION-A	100
SECTION 6 / SERVICE AND REPAIR	101
HOW TO SERVICE AND REPAIR THIS DEHUMIDIFIER	101
SECTION 7 / FORMALITIES AND GENERAL/LEGAL INFO	113
WARRANTIES	113
LEGAL NOTICES	114
EU DECLARATION OF CONFORMITY	115
HOW TO UPDATE AND IMPROVE THIS CONDAIR DEHUMIDIFIER	117
WHO TO CONTACT	118
ELECTRICAL DIAGRAMS	APPENDIX

SECTION 1 / GENERAL BACKGROUND

ABOUT THIS HANDBOOK

This is the installation and service handbook for your Condair dehumidifier.

You should read the whole handbook before installing and/or starting the dehumidifier unit for the first time. It is important that you and your colleagues are familiar with the correct operating procedures and all precautionary safety measures, in order to avoid any damage to the surroundings, materials or installations, as well as to prevent any personal injury.

This handbook is mainly intended for use by technicians who install and operate this Condair dehumidifier unit, who carry out preventive maintenance and who replace defective parts.

Anyone using Condair dehumidifier units, or whose responsibilities include supervising their operation, will also benefit from reading this handbook and from consulting it as a practical help should the need arise.

Product number for this handbook

The product number of this particular service handbook is XXXXXXXX.

This is the number you need to give us if you would like to order additional copies for your staff, colleagues or service personnel, or for technical staff from outside your company.

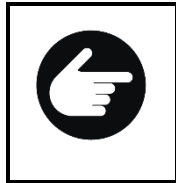
SYMBOLS USED IN THIS HANDBOOK

This tells you to perform a particular action

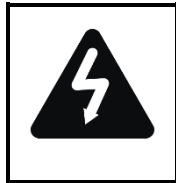

Important to note, because items in the dehumidifier can cause injury or affect people's health



You need to pay special attention to this

**NOTE**

It is each operator's responsibility to read and understand this manual and other information and to employ the correct operating and maintenance procedures.

ABOUT MANAGING HUMIDITY

Condair humidity management technology – cost-effective and energy-efficient

The moisture in the air all around us has surprising – and often costly – effects on the materials, structures and processes at the heart of virtually all business processes and industrial activity.

Condair humidity management technologies enable you to control the levels of moisture in the air inside any building, installation or facility, using only a bare minimum of energy.

And effective control of the basic parameters for your operations is good business.

ABOUT CONDAIR

World leader

Condair is one of the world's leading experts in the field of adsorption dehumidification, providing technology and expertise that enable companies to achieve better control of the humidity always present in the air.

Better management of the humidity in the air also makes it possible to improve and optimise a wide range of industrial processes, prevent damage and corrosion in many types of structures, and reduce energy consumption in all kinds of installations where air specifications are important.

Big benefits

Condair dehumidification units provide exceptional advantages.

- Our know-how and experience make sure each customer gets the right equipment to tackle all the practical needs and operating priorities associated with the specific installation
- Our units are exceptionally reliable, and can withstand even harsh treatment unusually well
- They are very easy to maintain and service
- They only use a minimum of energy in order to achieve maximum effect.

We aim to provide our customers with the most technically effective and energy-efficient solution for the best price. This ensures the best possible return on investment, as well as peace of mind about having made the best decision.

SECTION 2 / THE DEHUMIDIFIER

ABOUT THE CONDAIR DA 65E/DA 65D/DA 65C RANGE OF DEHUMIDIFIERS

The Condair DA 65E/DA 65D/DA 65C range of dehumidifiers is designed and configured for a wide range of industrial uses. Prominent among these is humidity management in storage facilities and basement areas, in water works and in many kinds of process industry in which stable, well-controlled air conditions are crucial.

DA 65E units are specifically configured to minimize the overall energy consumption of the dehumidification process, whereas DA 65D units are configured to make sure the air flow is as dry as possible.

The dehumidifiers in the DA 65E / DA 65D / DA 65C range are designed for easy cleaning, with configuration options that include cooling/heating coils and/or a heat recovery module and a condensation module and additional filters, if needed.

Design priorities

The Condair DA 65E / DA 65D / DA 65C range features an eye-catching modern industrial design appearance, along with exceptional reliability.

It is designed to ensure the unhindered passage of air through the unit, which reduces

- energy consumption
- pressure losses
- noise levels

All the components, ancillary equipment and features are optimised for better performance, exceptional service life and ease of maintenance.

Capacities

The Condair DA 65E / DA 65D range currently features models with air volumes of between 1100 m³/hour and 3700 m³/hour.

At process air inlet conditions of 20°C and 60% relative humidity (%RH), the capacities (the amount of water which can be removed from the air) of these units are between 7.1 kg/hour and 19.1 kg/hour.

Configuration priorities

The Condair DA 65E / DA 65D range is available with four different control configurations – Configuration-A, Configuration-B, Configuration-C and Configuration-D.

Control configuration-A is stripped down to a minimum of features and is therefore not equipped with a PLC screen interface.

Configuration-A/BASIC

The Configuration-A configuration provides:

- High dehumidification capacity
- High energy efficiency
- Stainless steel cabinet
- Easy installation
- Low-noise running
- Low maintenance costs, reducing the overall operating cost
- Easy cleaning
- Hour counter, to keep track of how long the unit has been in operation
- Attachment of external humidity sensor (external humidity control and sensors are not included as standard, but are available for purchase from Condair)
- Mechanical hour counter, to keep track of how long the unit has been in operation
- Over-heating alarm
- Remote start/stop option

Configuration-B

In addition to the Configuration-A features, the Configuration-B provides:

- Attachment of one external humidity sensor
- 3.5-inch touch display
- Service indication, to keep track of any need for maintenance
- Hour counter, to keep track of how long the unit and components has been in operation
- Mechanical service alarm for rotor and filters
- Control of regeneration air fan, making installation easier
- Capacity control / modulating heat control
- Measuring and controlling dew point temperature
- Data logging for keeping track of conditions in the space where the unit is installed
- Timer program
- Network connectivity (optional)
- Monitoring and control via smartphone app (optional)
- Monitoring and control by Condair service centre (optional)

Configuration-C

In addition to the Configuration-A and Configuration-B features, the Configuration-C provides:

- Control of process air fan, making installation easier
- Monitoring and control of air flows [m³/hour]
- Energy-saving program, for situations where energy consumption is the prime consideration
- Low-noise program, for situations where silence is the prime consideration
- CUSTOM program, for situation where dehumidifier parameters needs to be controlled

Configuration-D

In addition to the Configuration-A and Configuration-B features, the Configuration-D provides:

- Accurate control of humidity level, whether % relative humidity or specific humidity [g/kg]
- Continuous measurement of capacity
- Detailed energy-saving program, for situations where energy consumption is the prime consideration

Operating conditions

For the process and regeneration air inlet, the following operating conditions must be respected:

Relative humidity	0–100%
Temperature	0–40°C
Pressure	Ambient \pm 100 Pa

It is only possible to deviate from these ranges if such deviations were specifically mentioned when the order was placed, and special considerations have been incorporated into the unit in order to deal with this.

**NOTE**

Operating conditions for the air inlet flows must be respected.

Storage conditions

For storing the dehumidifier, the following conditions must be respected:

Relative humidity	0–90%
Temperature	-20°C to 50°C

It is only possible to deviate from these ranges if such deviations were specifically mentioned when the order was placed, and special considerations have been incorporated into the unit in order to deal with this.

**NOTE**

Storage conditions for the dehumidifier must be respected.

HOW IT WORKS

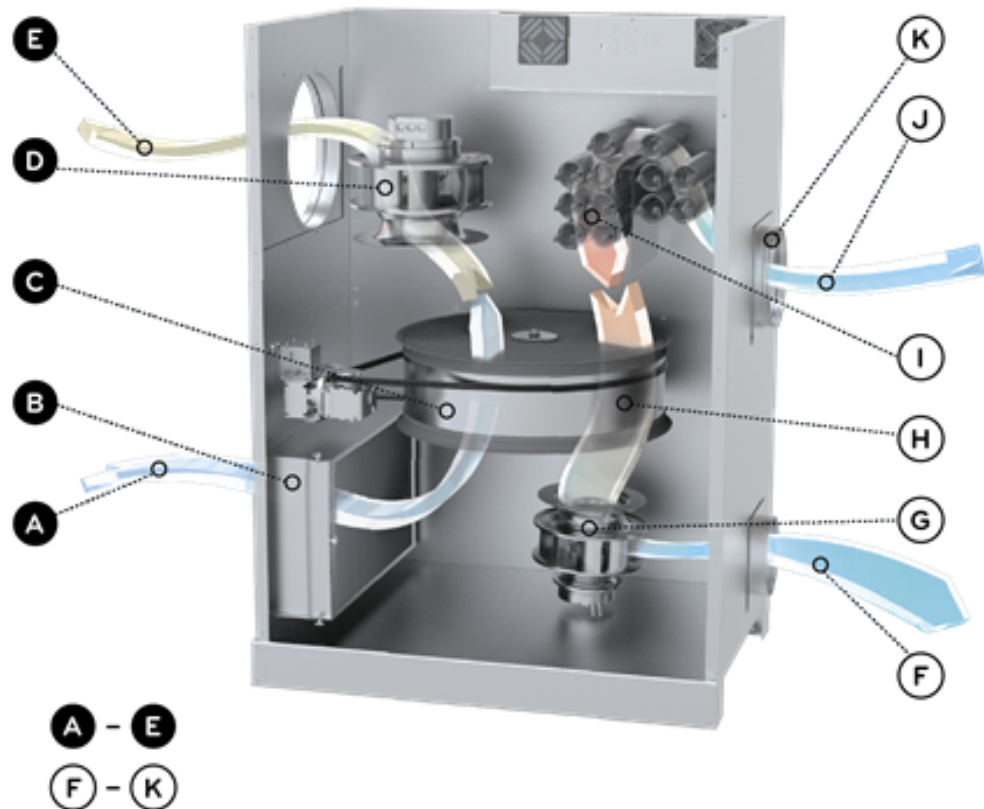

Two flows of air

The effect of Condair adsorption dehumidifiers basically stems from the action of two flows of air.

The drying process (A to E)

The incoming moisture-laden flow of air (process air) (A) enters one side of the cabinet and gets filtered by a process air filter (B). The air then passes through a slowly turning rotor (C) whose inner surfaces are coated with desiccant silica crystals that attract the water molecules passing through.

When the moist air passes through the rotor, water molecules are adsorbed and lodge in the pores on the surface of the silica gel. This means the air leaves the rotor containing less moisture (humidity) than when it entered (E). And because the adsorption process releases energy to the air, the temperature increases during the process. The process air is controlled by a process air fan (D).

The regeneration process (F to K)

The second air flow (the regeneration air) (J) is filtered by a regeneration air filter (K), and heated by heating elements (I) to reduce its relative humidity. On its way through the rotor (H), this heat evaporates the moisture previously adsorbed by the silica crystals in the rotor. The resulting water vapour now leaves the dehumidifier in the outgoing regeneration air (F). The regeneration air is controlled by a regeneration air fan (G).

Fans

All units in the DA 65E / DA 65D / DA 65C range of adsorption dehumidifiers are fitted with two fans as standard.

For the Configuration-B, the speed of the regeneration air fan can be controlled.

For the Configuration-C and Configuration-D, the flows of process air and regeneration air flows can be controlled manually or automatically (standard).

Condair adsorption dehumidifiers are always configured with a certain amount of "external pressure" to make sure that ducting does not cause a reduction in the amount of air.

For details about the fans fitted to this particular Condair dehumidifier, see page 29.

Filters

All models of Condair adsorption dehumidifiers are fitted with filters to remove undesirable particles or other pollutants from the incoming process and regeneration air.

Filters of the G4 class are fitted to Condair DA 65E / DA 65D / DA 65C units as standard in order to filter the incoming process air.

For details about the filters fitted to this particular Condair dehumidifier, see page 29.

Heating units

Condair DA 65E / DA 65D / DA 65C dehumidifiers are fitted with electrical heating units as standard, in order to control the temperature of the regeneration air entering the unit.

For details about heating units fitted to this particular Condair dehumidifier, see page 29.

Post-heating units

Being able to control the exact specifications of the air leaving the dehumidifier enables you to extract maximum benefit from Condair humidity management.

If it is important to keep the process air at a consistently high temperature, a post-heating unit can be fitted after the adsorption rotor, as optional equipment.

A post-heating unit is normally in combination with a post-cooling coil, in order to ensure 100% control of both relative humidity and temperature.

Post-heating units can be retrofitted to DA 65E / DA 65D dehumidifiers with the Configuration-B, Configuration-C and Configuration-D.

For details about any post-heating units fitted to this particular Condair dehumidifier, please contact your Condair dealer, or Condair.

Pre-cooling units

Being able to control the exact specifications of the air entering the dehumidifier enables you to extract maximum benefit from Condair humidity management.

Condair DA 65E / DA 65D / DA 65C dehumidifiers can therefore be fitted with cooling units to reduce and/or control the temperature of the dry air entering and leaving the dehumidifier.

A cooling unit fitted before the adsorption rotor is particularly beneficial if the incoming process air is very warm and humid. In such cases, some of the water in the air condenses and the efficiency of the adsorption rotor increases. A cooling unit fitted before the adsorption rotor can also be an advantage if the outgoing process air has to be especially dry.

Pre-cooling units can be retrofitted to DA 65E / DA 65D dehumidifiers with the Configuration-B, Configuration-C and Configuration-D.

For details about any pre-cooling units fitted to this particular Condair dehumidifier, please contact your Condair dealer, or Condair.

Post-cooling unit

Condair DA 65E / DA 65D units can be fitted with post-cooling/heating units to maintain full control of the temperature of the dry air leaving the dehumidifier.

Post-cooling/heating units can be retrofitted to DA 65E / DA 65D dehumidifiers with the Configuration-B, Configuration-C and Configuration-D.

For details about any cooling units fitted to this particular Condair dehumidifier, please contact your Condair dealer, or Condair.

Heat recovery unit (HR module)

Condair adsorption dehumidifiers can be fitted with a heat exchanger to make sure that part of the thermal energy from the regeneration air leaving the unit is extracted, and reused for preheating the incoming regeneration air.

The heat exchanger is placed in an external box equipped with inlets and outlets for the incoming and outgoing regeneration air.

The heat recovery unit can save as much as 20 % on energy consumption, and can be fitted to all configurations of DA 65E / DA 65D dehumidifiers.

The heat recovery unit can be fitted to DA 65E / DA 65D dehumidifiers with the Configuration-A, but you have to install the appropriate ducting and damper for outgoing regeneration air.

For details about the heat recovery unit fitted to this particular Condair dehumidifier, please contact your Condair dealer, or Condair.

Water condensation unit (LK module)

Condair adsorption dehumidifiers can be fitted with water condensation units in order to condense some of the water from the regeneration air leaving the dehumidifier. This is beneficial when a regeneration air outlet is not a good idea or cannot be fitted.

When a water condensation unit is installed, the regeneration air forms a closed circuit, using ambient air passing through heat exchangers to cool the regeneration air to below condensation temperature.

A water condensation unit can be fitted to all configurations of DA 65E / DA 65D dehumidifiers. In Configuration-A, the dehumidifier must be fitted with a dedicated Reg. Air Fan Kit in order to reduce the regeneration air flow for optimal performance.

For details about the water condensation unit fitted to this particular Condair dehumidifier, please contact your Condair dealer, or Condair.

FEATURES AND BENEFITS

Highlighted features	How customers benefit
Appearance/cabinet	
Eye-catching industrial design appearance.	Visually attractive units that can be mounted in highly visible positions.
Robust structure.	Longer service life. Better return on investment.
Equipment configurations inside the cabinet	
All fans are mounted inside the cabinet.	Can be mounted in a wider range of positions and structures, even where there is public access, etc.
Easy to mount additional insulation and noise suppression equipment.	Configurations individually customised to each project/installation.
Key components are standardised units easily available throughout the world.	Less downtime. Savings on maintenance and service work.
Most effective rotor currently available anywhere in the world.	Most humidity removed from the flow of air at lowest cost.
Highly durable rotor bushes.	Savings on maintenance and service work. Greater operating efficiency.
Air flow	
Available with frequency-controlled ventilator.	Savings on energy costs. Less noise

Access	
Large door that provide rapid, easy access.	<p>Savings on maintenance and service work.</p> <p>Less downtime means greater operating efficiency.</p>
Filters that are easy to get out, and quick to change.	<p>Savings on maintenance and service work.</p> <p>Greater operating efficiency.</p>
Connectivity	
<p>Compatible with all standard electrical voltages and frequencies</p> <ul style="list-style-type: none"> • 230V/400V/440V • 50Hz/60Hz. 	<p>Savings on installation costs.</p> <p>More rapid commissioning.</p>
Designed for compatibility with modern PLC and web-based control and warning systems.	Easy to control and monitor from virtually anywhere.
Modular design prepared for installation of control systems, heaters, cooling systems, hygrometers, sensors, etc.	<p>Rational, cost-effective dehumidification installations.</p> <p>Maximum reliability.</p>
Energy sources	
Thermal recovery installations can be fitted.	<p>Savings on energy costs</p> <p>Improved environmental footprint.</p>

SECTION 3 / TECHNICAL DETAILS

SERIAL NUMBER/IDENTIFICATION

This is the installation and service handbook for your Condair dehumidifier.

The serial number/identification code for your particular model is located in the top right corner of the right side of the dehumidifier (see drawing below).

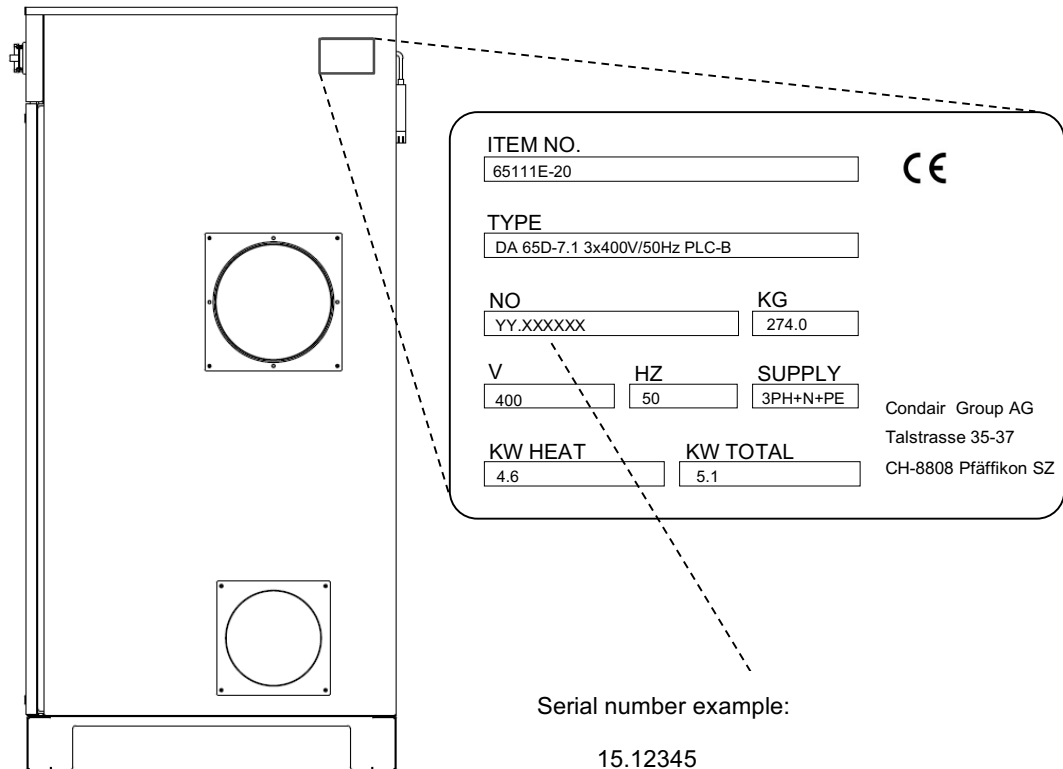

SPECIFICATIONS

Please note that specifications and controls given in this handbook are in some situations approximate.

Table 1 Technical data DA 65E / DA 65D

Type		DA 65E				DA 65D			LK
	Model	7.8	11.1	15.4	19.1	7.1	10.1	14.0	-
Dry air, nominal** [m ³ /hour]		1900	2600	3700	3700	1100	1500	2200	-
Regen. air, nominal* [m ³ /hour]		340	460	670	940	340	460	670	-
External pressure, dry air [Pa] (at nominal air flow)		400	400	500	500	400	400	400	-
External pressure, regen. air [Pa] (at nominal air flow)		300	400	400	400	300	400	400	-
Capacity at 20°C, 60% relative humidity [Kg/hour]		7.8	11.1	15.4	19.1	7.1	10.1	14.0	-
Electric heater, max. [Kw]		10.2	14.4	20.4	28.8	10.2	14.4	20.4	-
Maximum Fuse [A] (3x230V)		63 (63)	63 (63)	63 (63)	63 (80)	63 (63)	63 (63)	63 (63)	
Minimum Fuse [A]		35	35	50	63	20	35	50	-
Nominal power consumption [kW]		11.4	16.2	23.6	32.4	11.1	15.7	22.5	-
Voltage [V]		400							-
Frequency[Hz]		50							-
Ground		3PH+PE							-
Sound level with duct (ISO11201) [dB(A)]		61	67	73	73	<61	<61	<67	-

Table 2 Measurements

Type		DA 65E				DA 65D			LK	HR
	Model	7.8	11.1	15.4	19.1	7.1	10.1	14.0	-	-
L x W x H cabinet	mm	786 x 1164 x 1615							-	780 x 680 x 1613
L x W x H total	mm	819 x 1268 x 1628							-	782 x 724 x 1630
Weight	kg	274	300	300	305	274	300	300	-	112
Regeneration air outlet	mm	200x200 (ø200)								
Regeneration air inlet	mm	250x250 (ø250)								
Process air inlet	mm	650x400 (ø400)							-	-
Process air outlet	mm	650 x400 (ø315)	650x400 (ø400)			650x400 (ø315)		650 x400 (ø400)	-	-
Drain size	inch	-							-	1/2"

* Adjustable in Configuration-B and fully controlled in Configuration-C and Configuration-D.

Also adjustable in Configuration-A with Reg. Air Fan Kit installed.

** Fully controlled in Configuration-C and Configuration-D.

Table 3 Technical data DA 65C

Type		DA 65C	
	Model	1.6	3.2
Dry air, nominal**	m ³ /hour	1900	3700
Regeneration air, nominal*	m ³ /hour	340	340
External pressure, dry air (at nominal air flow)	Pa	400	400
External pressure, regeneration air (at nominal air flow)	Pa	300	300
Capacity at -25°C, 90% relative humidity	kg/hour	1.6	3.2
Capacity at -18°C, 90% relative humidity	kg/hour	X	X
Electric heater, max.	kW	5.1	7.2
External duct heater, max.	kW	1.0	1.0
Fuse (3x230V)	A	20	20
Maximum connected load	kW	10	10
Voltage (3x230V)	V	400 (3x230)	400 (3x230)
Frequency	Hz	50	50
Ground (3x230V)		3PH+N+PE (3PH+PE)	3PH+N+PE (3PH+PE)
Sound level with duct (ISO11201) [dB(A)]	dB(A)	61	73

Capacities

Figure 1 DA 65E-7.8 capacity at 1900 m³/hour

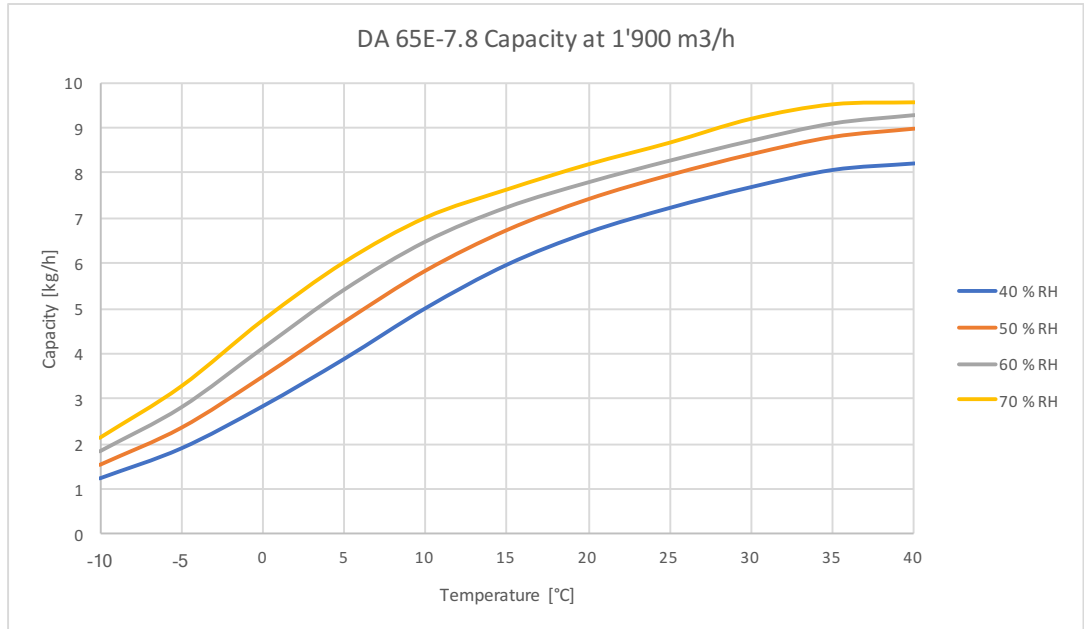

Figure 2 DA 65E-11.1 capacity at 2600 m³/hour

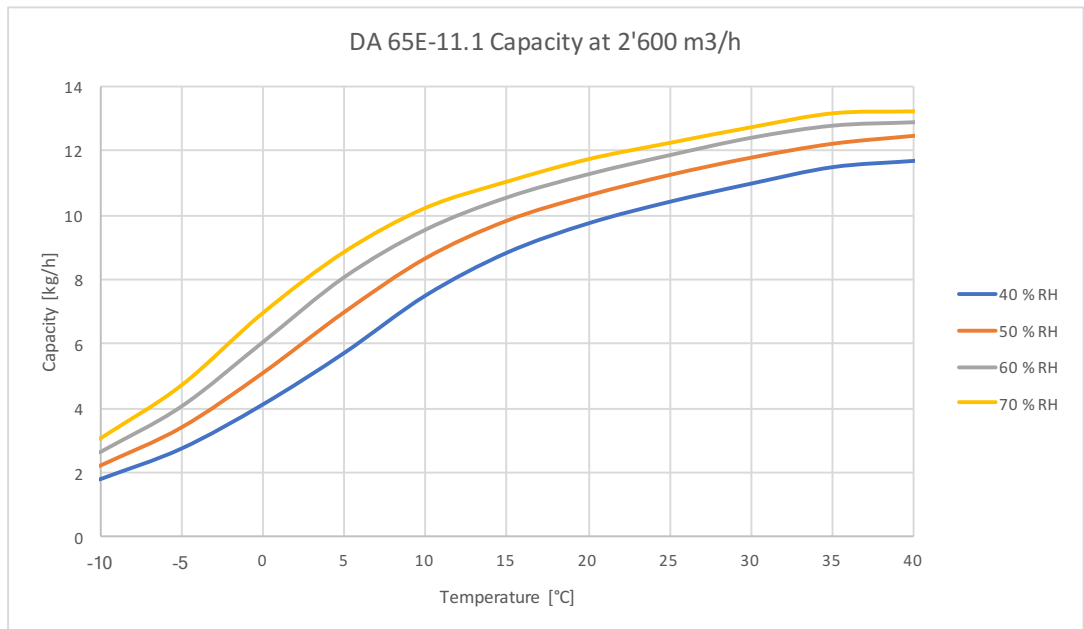

Figure 3 DA 65E-15.4 capacity at 3700 m³/hour

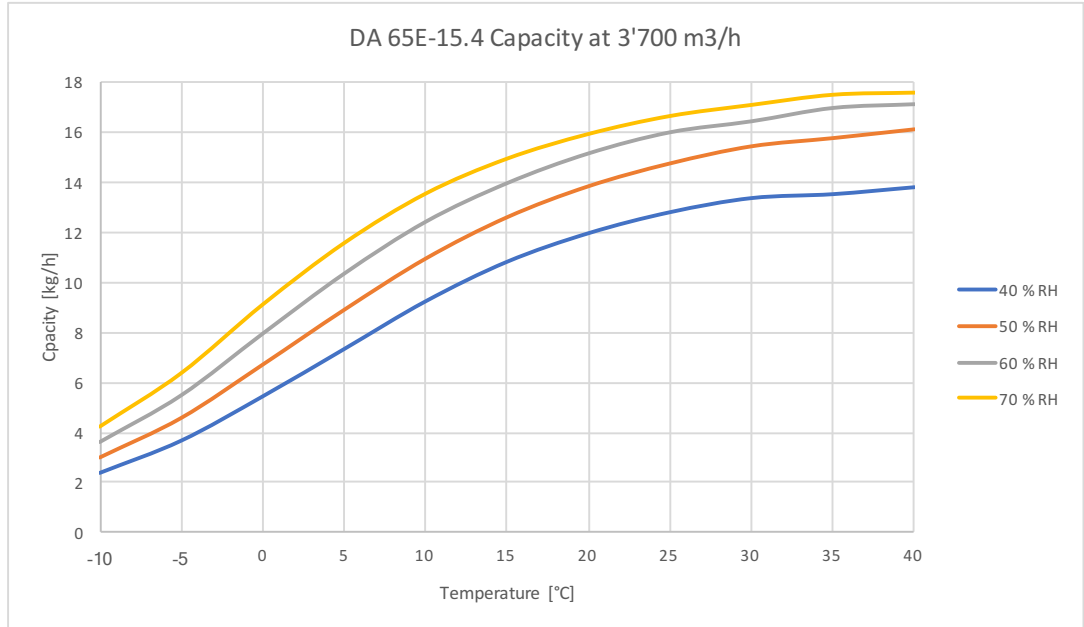

Figure 4 DA 65E-19.1 capacity at 3700 m³/hour

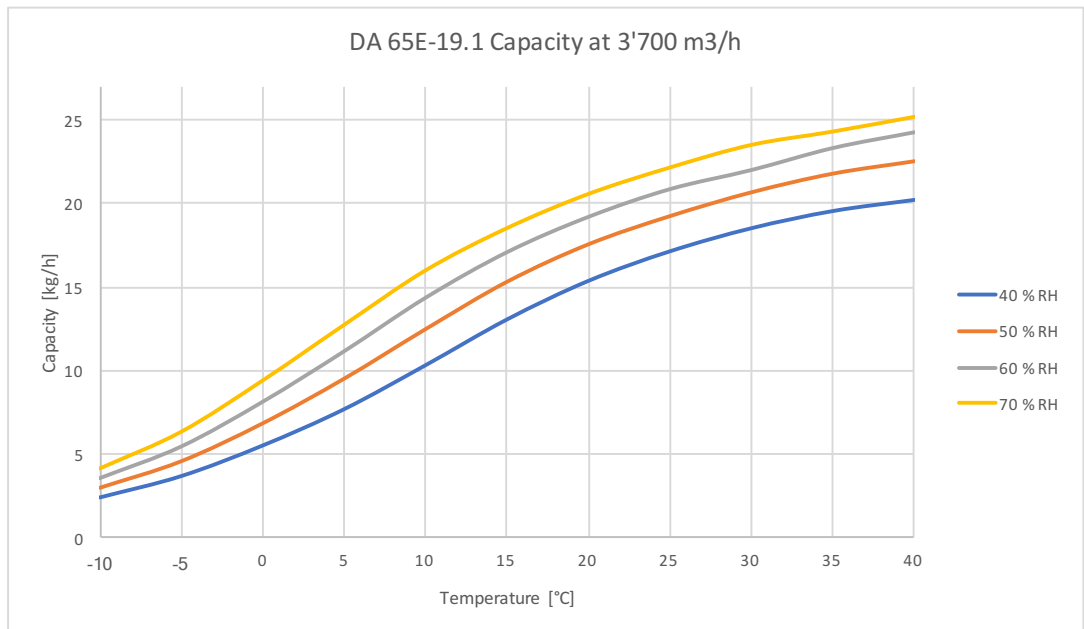

Figure 5 DA 65D-7.1 capacity at 1100 m³/hour

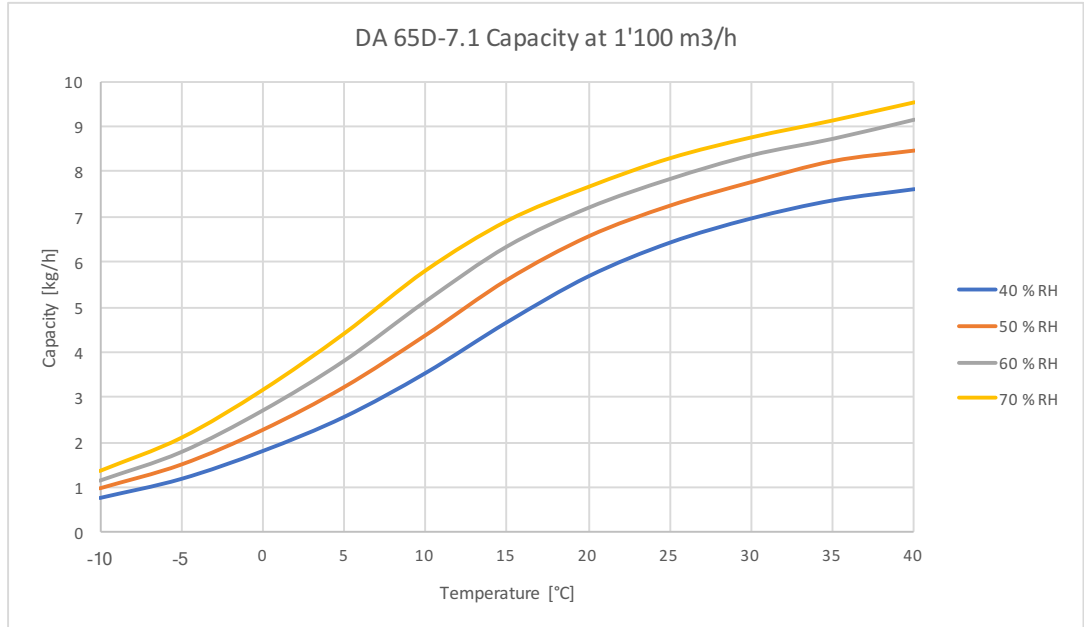

Figure 6 DA 65D-10.1 capacity at 1500 m³/hour

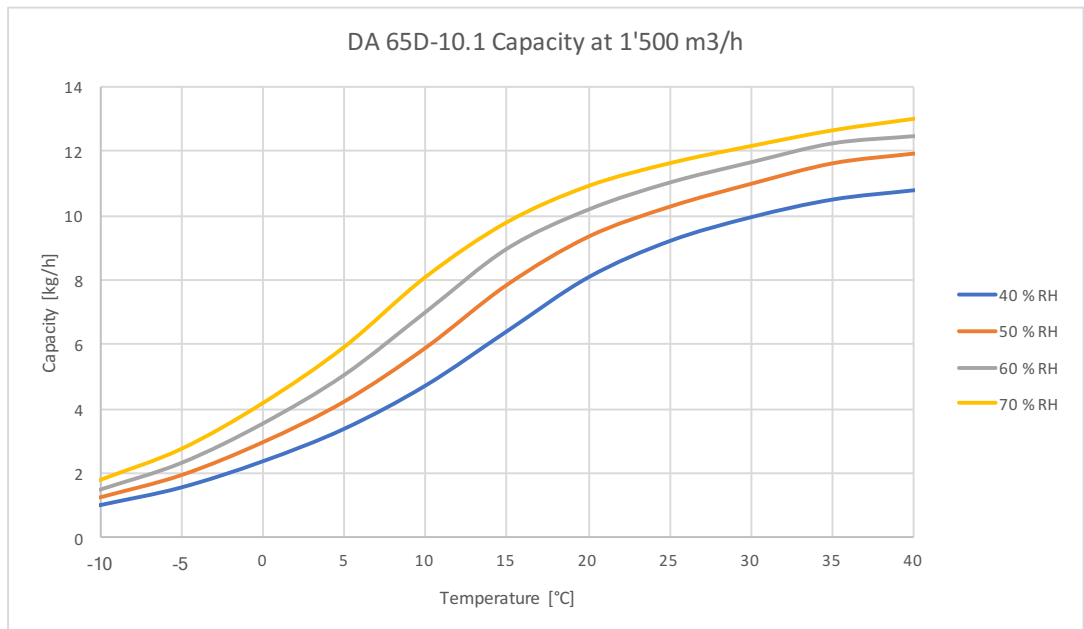
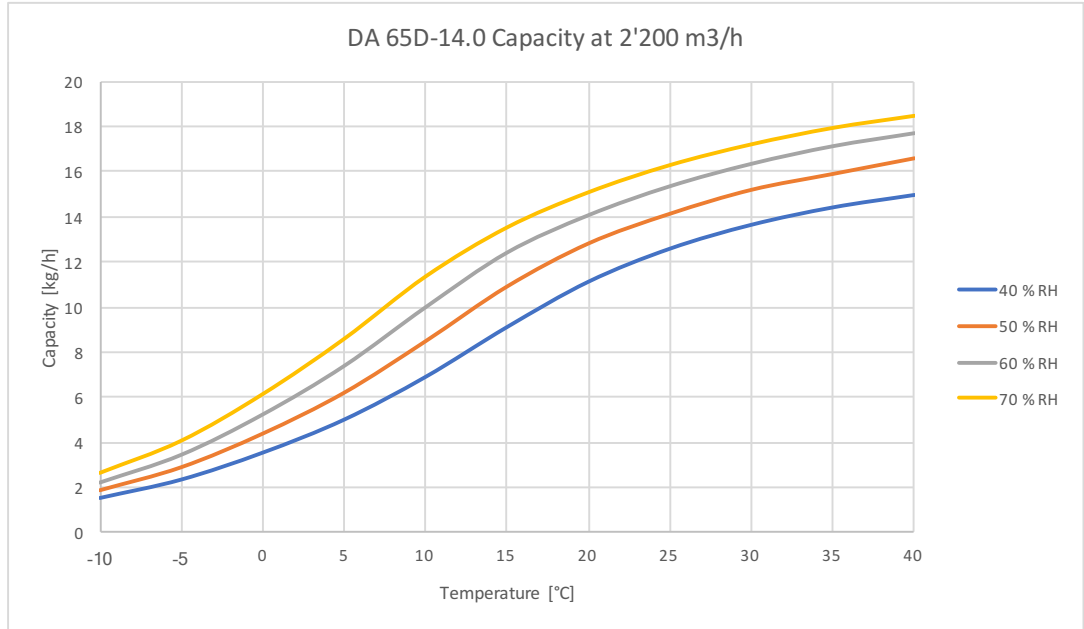

Figure 7 DA 65D-14.0 capacity at 2200 m³/hour



ASSEMBLIES AND COMPONENTS

Customised to meet your needs

Condair dehumidifier units are based on a modular design that enables our customers to select from a broad range of carefully selected components and assemblies, to meet specific installation and operating requirements.

Your Condair DA 65E / DA 65D / DA 65C dehumidifier has been configured to meet the particular requirements of your installation.

Dimensions

DA 65E / DA 65D / DA 65C dehumidifier

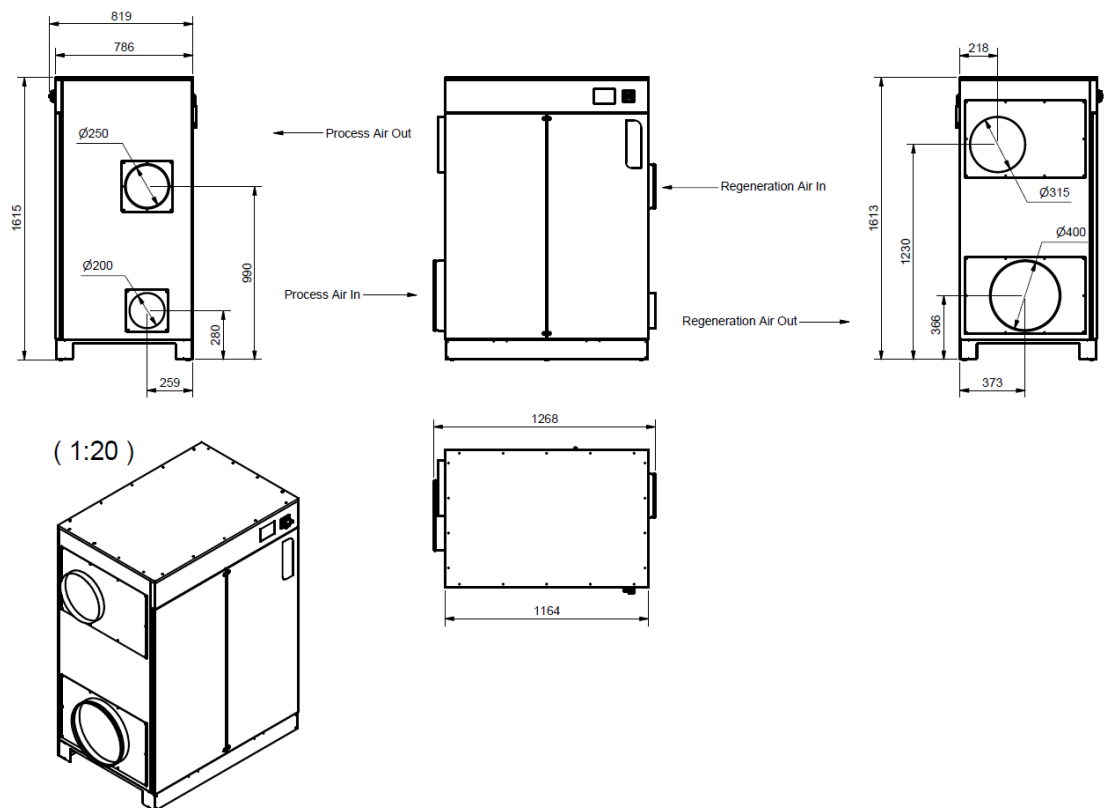

Heat recovery module

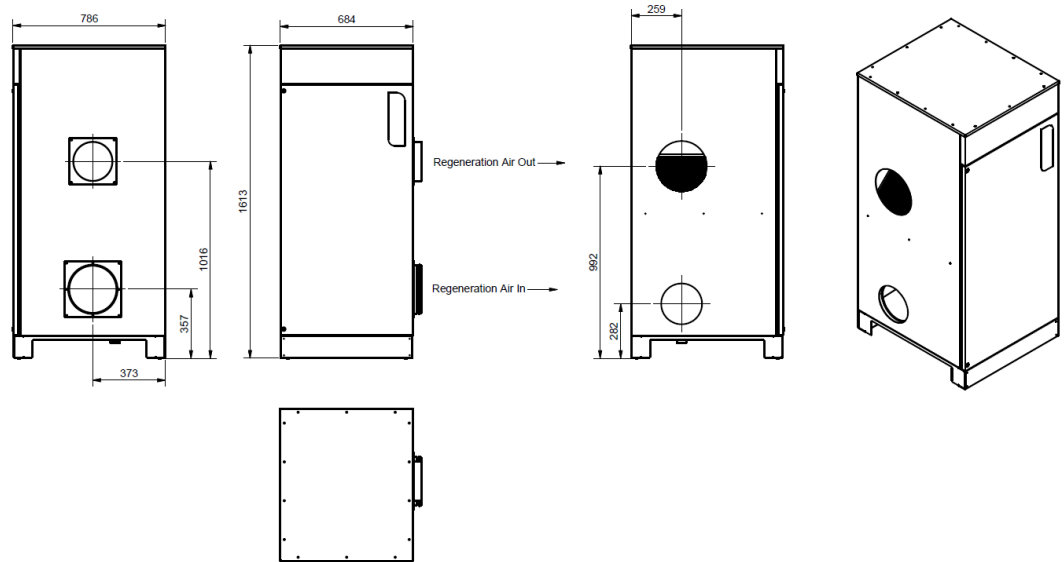

Spare parts

DA 65E/DA 65D/DA 65C dehumidifier

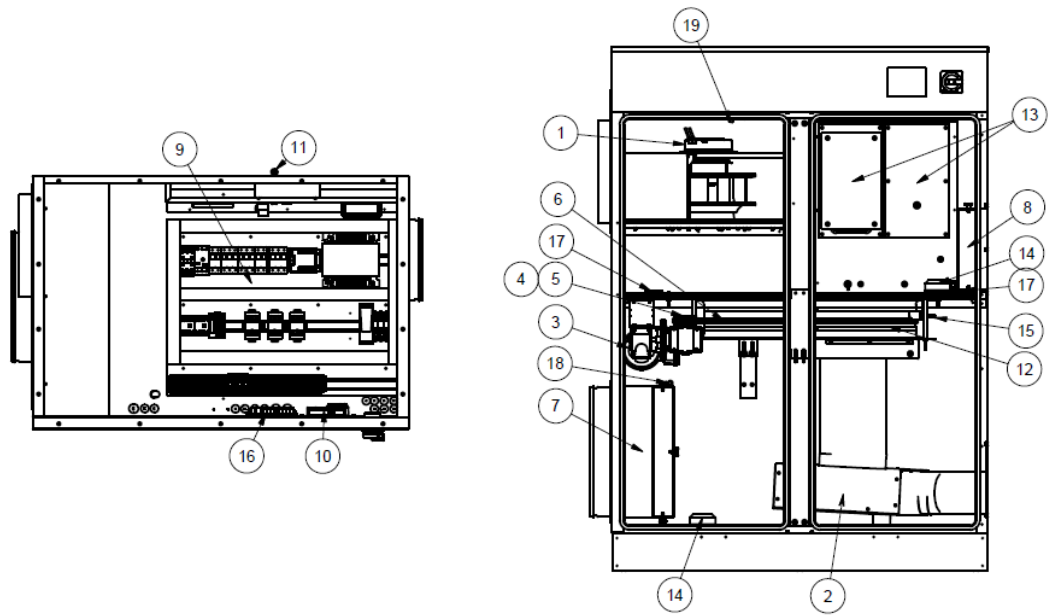

Heat recovery module

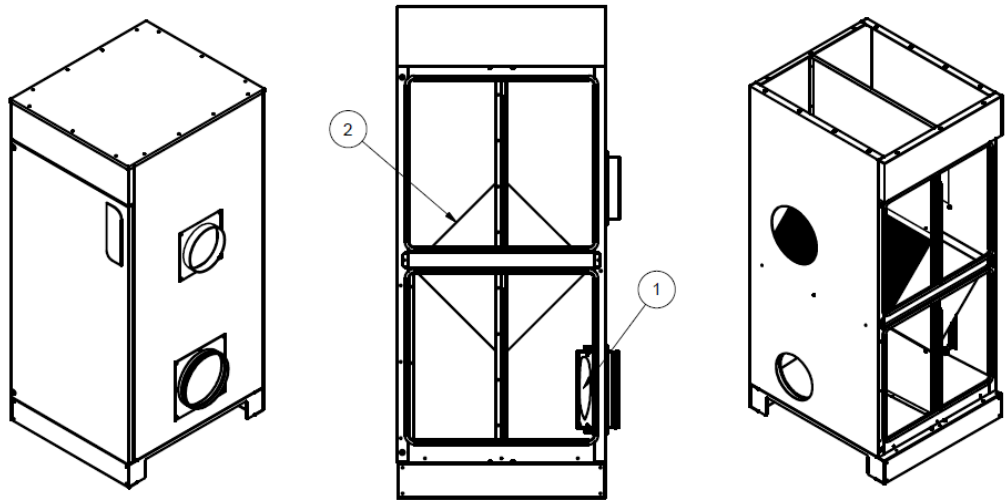

Table 4: Spare parts list DA 65E / DA 65D / DA 65C / LK / HR

Pos	Type	DA 65E				DA 65D			DA 65C	
		7.8	11.1	15.4	19.1	7.1	10.1	14.0	1.6	3.2
1	Process air fan	801699	801670	801670	801670	801667	801699	801670	801699	801670
2	Regeneration air fan in cabinet	614371	620527	620527	620710	614371	620527	620527	614371	614371
3	Gear motor	110467	110466	110467	110468	110467	110466	110467	110467	110467
4	Pulley	127005	127014	127005	127187	127005	127014	127005	127014	127014
5	Taper bush	127007	127007	127007	127007	127007	127007	127007	127007	127007
6	Drive belt	132108							132108	132108
7	Process filter	130372							130372	130372
8	Regeneration air filter	130373							130373	130373
9	Electric board (400V)	620519	620519	620754	620754	620519	620519	620754	620750	620750
10	PLC	140621							-	-
11	Humidity sensor	140639							-	-
12	Rotor	124040	124211	124211	124211	124040	124211	124211	124040	124211
13	Heaters	111505 (6pcs)	111514 (6pcs)	111505 (7+5pcs)	111514 (6+5pcs)	111505 (6pcs)	111514 (6pcs)	111505 (7+5pcs)	111505 (3pcs)	111514 (3pcs)

Configuration-B				
14	Pressure switch for filters	126843		
15	Rotor guard	111597		
Configuration-C + Configuration-D				
16	I/O board	112086		
17	Pressure switch for rotor	140624		
Configuration-D				
18	Process air in sensor	140625		
19	Process air out sensor	140626		
HEAT RECOVERY UNIT				
1	Regeneration air filter	130373		
2	Heat exchanger	126959		

SOUND LEVELS

Sound dampening and silencers

Please check the maximum sound level permitted for the particular installation you are working with, and select the sound dampening and silencers needed for the dry air outlet duct and the regeneration air outlet duct accordingly.

Measuring sound levels

Sound levels for Condair dehumidifiers are measured in accordance with the provisions of the ISO11201 standard.

While the sound level is being measured, the dehumidifier is placed on the floor. Ducts for regeneration air and for incoming air/outgoing air are installed and led out of the measuring room.

The sound level is then measured 1 metre outside the front of the cabinet (outside the large cabinet cover), and 1.6 metres above the floor.

SECTION 4 / INSTALLATION

HOW TO INSTALL THIS DEHUMIDIFIER

Removing the packaging

Condair DA 65E / DA 65D / DA 65C dehumidifier units are delivered in a cardboard box. Please dispose of this packaging responsibly, and recycle it if possible.

Handling

Condair dehumidifiers are built to be very robust, so there is no need for special handling, apart from normal sensible care and attention.

Note the weight of the dehumidifier as specified on page 19. We recommend that you use a forklift to move the dehumidifier around and place it in position.

Where to mount this dehumidifier

Condair adsorption dehumidifiers are designed for installation indoors.

The back of the dehumidifier should be placed against an outer wall to make it easier to install the regeneration air ducts.

The three other sides of the unit should have at least 1 metre of unobstructed access, for easy service and maintenance.

Where not to mount it

Unless it has been arranged with Condair and special considerations have been made, the unit should not be placed outdoors.

The unit should not be placed inside an office or in other locations where the sound pressure level must be kept to a minimum.



NOTE

Dehumidifier must be placed indoors, and protected from rain and water.

Things to be careful about

Electrical work should only be carried out by an authorised electrician.

**NOTE**

Electrical work should only be carried out by an authorised electrician.

Connections needed – electrical

First, make sure that the main switch is OFF.

**NOTE**

Make sure power is switched off before installing and servicing.

Now the power circuit cable can be connected to the main switch of the dehumidifier.

Connections needed – ductwork**NOTE**

To ensure low pressure drop and low sound pressure levels, please request assistance from a company that specialises in ductwork.

The ductwork for the process air should be selected with regard to the external pressure available from the process air fan and the space available for ducting.

A 315mm or 400mm-diameter duct is normally recommended for the process air flow.

When installed, the process air flow should be adjusted by means of a damper.

In Configuration-C and Configuration-D, the process air fan is equipped with a frequency converter, which makes dampers on the process air side unnecessary.

The regeneration air should be led to and taken from the outdoors.

The ductwork for the regeneration air should be selected with regard to the external pressure available from the regeneration air fan and the space available for ducting.

A 200mm or 250mm-diameter duct is normally recommended for the regeneration air flow.

The regeneration air outlet should be made to drain downwards towards the outlet, to allow any condensate to run out. If a reduction is needed at the regeneration air outlet, the reducer must be eccentric enabling condensation being led out throughout the ductwork.

There must be at least 500mm unrestricted access above the dehumidifier for easy access.

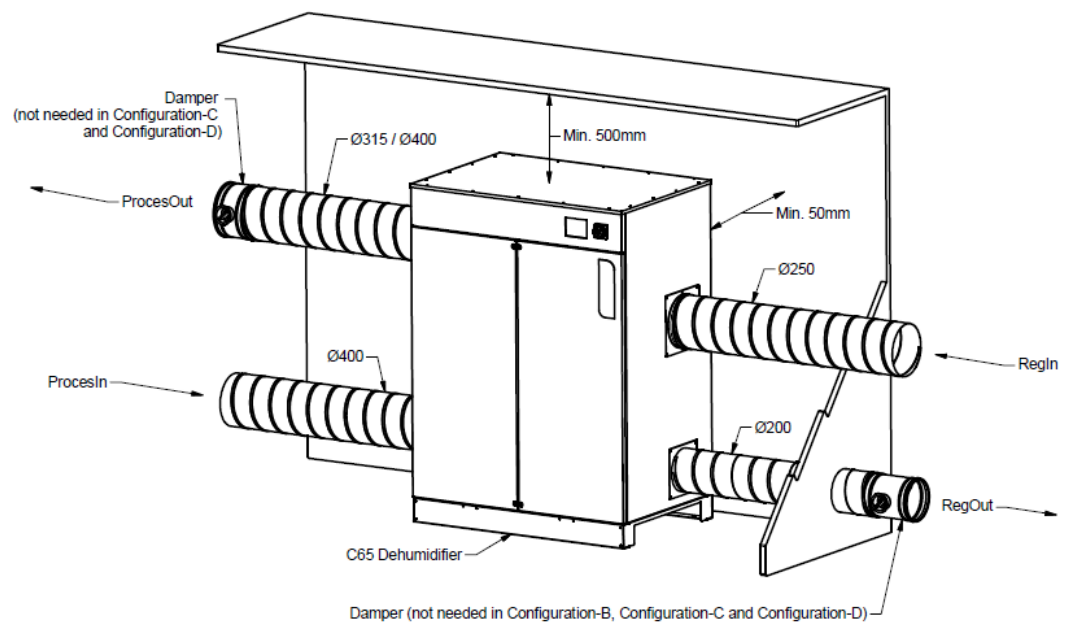

If this draining downwards is not possible, drill a $\varnothing 6\text{mm}$ hole in the lowest part of the duct, so that any accumulated water can drain away.



NOTE

The regeneration air outlet should be made to drain downwards towards the outlet for draining.

If this is not possible, drill a $\varnothing 6\text{mm}$ hole in the lowest part of the duct, so that any accumulated water can drain away.

A damper for adjusting the regeneration air flow must be installed on the outlet in order to adjust the regeneration air flow. If not, the regeneration air flow will – in most cases – be too high, making it impossible to reach the desired temperature for the regeneration air and thus making the unit less efficient. Use a standardised tool for measuring the velocity according to specifications.

In Configuration-B, Configuration-C and Configuration-D, the regeneration air fans are equipped with frequency converters, which makes dampers on the regeneration air side unnecessary. In Configuration-C and Configuration-D, the flow of process and regeneration air will adjust automatically.

Safety precautions

Dehumidifiers in the DA 65E / DA 65D / DA 65C range weigh approximately 274–305 kg and should therefore only be moved using a forklift or similar equipment

Any work in the electrical box should only be carried out by authorised electricians.

Any duct connections to and from the dehumidifier should only be carried out by authorised plumbers.

HOW TO INSTALL A CONDENSATION UNIT OR HEAT RECOVERY UNIT

Removing the packaging

Condair condensation units (LK module) and heat recovery units (HR module) are delivered in a cardboard box. Please dispose of this packaging responsibly, and recycle it if possible.

Handling

Condair condensation units and heat recovery units are built to be very robust, so there is no need for special handling, apart from normal sensible care and attention.

Note that the weight of the condensation unit is 70 kg and the weight of the heat recovery module is 50 kg. We recommend that you use a forklift to move such units around and to place them in position.

Where to mount the condensation or heat recovery unit

The condensation and heat recovery units are designed for indoor installation mounted directly onto the Condair adsorption dehumidifier on the right side connecting the units to the regeneration air flow.

Note that both units cannot be mounted on the dehumidifier at the same time. The condensation or heat recovery unit must be installed 0–5 mm away from the DA 65 dehumidifier. The dehumidifier must have the duct connectors installed on both the regeneration air inlet and outlet before installing the water condensation or heat recovery unit.

Connection need for heat recovery unit - drain

The condensation unit LK is equipped with one drain connection that has to be guided to the drain in the building as minor condense may get formed inside the unit. It is possible to install an airlock in order to avoid infiltration of regeneration air into the room. The air lock has to be filled with water prior to use.

Connection needed for the condensation unit - drain

The condensation unit LK is equipped with two drain connections found on the bottom of the unit. The drain connection to the left (seen from the front) is the main drain. It may be relevant to add an airlock to this drain as humid air is floating from this connector, however, it is not a requirement. The air lock has to be filled with water prior to use. For the other drain an airlock is less relevant and this can be connected directly to the drain in the building.

**NOTE**

The two drain must not be connected by a Y connection and guided in one common hose to the drain in the building. Water has to float independently from each of the LK drain connections to the drain in the building.

Connections needed for the condensation unit – electrical

First, make sure that the main switch is OFF.

The condensation unit has a pre-mounted cable connected to the condensation air fan. This cable must be directly connected to the terminals 106X2 in the electrical board located in the DA 65 dehumidifier.

Option 1 – older models

In order to enable the LK unit in the PLC control: Mount a jumper in the electrical board terminal 106X3 in order to setup the DA 65 dehumidifier for the condensation unit configuration. A text showing “LK MODULE” is found in the “Overview menu/screen” when the cable is installed. For further information, please consult the electrical diagram on page 106.

Option 2 – newer models

In order to enable the LK unit in the PLC control: Goto main menu – Setup – Advanced and press the “LK module” button. The button will light up and a text showing “LK MODULE” is found in the “overview menu/screen”. For further information, please consult the electrical diagram on page 106.

Connections needed for the condensation unit in DA 65 Configuration-A – electrical

The DA 65 Configuration-A has no built-in regeneration fan adjustment and cannot control the regeneration air fan speed, which is needed when installing the condensation unit.

A Reg Air Fan Kit is therefore available for the DA 65 Configuration-A to make it possible to control the regeneration air fan using a potentiometer.

When the Reg Air Fan Kit is installed, make sure the main switch is OFF before continuing.

The condensation unit has a pre-mounted cable connected to the condensation air fan. This cable must be directly connected to the 106X2 terminal in the electrical board in the DA 65 dehumidifier.

When the 106X2 wire is connected, you should turn on the machine and start the dehumidifier.

Start by turning the potentiometer to its maximum position for full regeneration fan speed. Measure the amps at terminal 150X1-1 and measure the same amperage at terminals 150X-2 and 150X-3.

Adjust (decrease) the potentiometer slowly until the amps drop to 0A at terminal 150X-1. This means the heating set point has been reached, and you must increase the fan speed a little for most effective performance (corresponding to the heating always being on). Measure whether the amperage at terminal 150X-1 is the same as at terminals 150X-2 and 150X-3

HOW TO INSTALL A DA 65C (COLD STORE MODEL)

Removing the packaging

Condair DA 65C units are delivered in a wooden box. Please dispose of this packaging responsibly, and recycle it if possible.

Handling

Condair DA 65C units are built to be very robust, so there is no need for special handling, apart from normal sensible care and attention.

Note that the DA 65C unit weighs approximately 274 kg. We recommend that you use a forklift to move such units around and to place them in position.

Where to mount this dehumidifier

Condair DA 65C adsorption dehumidifiers are specially designed for installation inside cold storage facilities.

The back of the dehumidifier should be placed against the wall, with room for the regeneration air ducts to pass easily to and from the dehumidifier and out of the cold storage area.

The three other sides of the unit should have at least 1 metre of unobstructed access, for easy service and maintenance.

Where not to mount it

The unit must not be installed outside the cold storage space unless this has been arranged with Condair and special adjustments have been made to the unit.

Connections needed – electrical

First, make sure that the 1kW external heater is connected to 230V/50Hz and the external control current is connected to the electrical board, as described in the electrical diagram on page 300 for the DA 65C cold storage model. The external heater pre-heats the regeneration air before it enters the DA 65C dehumidifier.

The DA 65C electrical cabinet has a small built-in fan heater to protect all the electrical components from the cold storage temperatures. The fan heater operates for 30 minutes before the dehumidifier starts, as a safety precaution when the main switch is on.

**NOTE**

The DA 65C dehumidifier has a built-in fan heater in order to protect the electrical components. A 30-minute timer is activated when the main switch is turned on.

Connections needed – ductwork

The ductwork for the process air should be selected with regard to the external pressure available from the process air fan and the space available for ducting. A 315mm-diameter or 400mm-diameter duct is normally recommended for the process air flow.

When installed, the process air flow should be adjusted by means of a damper.

The regeneration air must be led to and taken from the outdoors. The ductwork must always be insulated from and to the cold storage. Such insulation is not included when purchasing a DA 65C dehumidifier.

The regeneration air outlet should be made to drain downwards towards the outlet, to allow any condensate to run out.

There must be at least 500 mm unrestricted access above the dehumidifier for easy access.

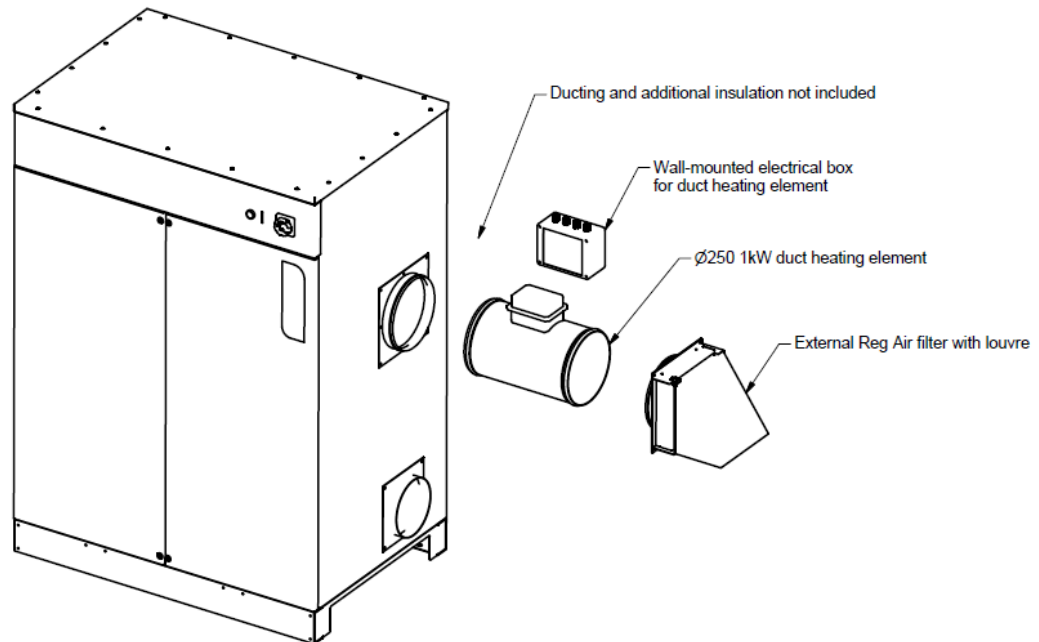

If this draining downwards is not possible, drill a $\varnothing 6\text{mm}$ hole in the lowest part of the duct, so that any accumulated water can drain away.



NOTE

The regeneration air inlet and outlet ductwork must be insulated at all times within the cold store. Furthermore, the external heater, filter frame and electrical box must be installed according to specifications.

A damper for adjusting the regeneration air flow must be installed on the outlet in order to adjust the regeneration air flow. If not, the regeneration air flow will – in most cases – be too high, making it impossible to reach the desired temperature for the regeneration air and thus making the unit less efficient. Use a standardised tool for measuring the velocity according to specifications.

Safety precautions

DA 65C dehumidifiers weigh approximately 274 kg and should therefore only be moved using a forklift or similar equipment

Any work in the electrical box should only be carried out by authorised electricians.

Any duct connections to and from the dehumidifier should only be carried out by authorised plumbers.

HOW TO COMMISSION THIS DEHUMIDIFIER



NOTE

Only trained/authorised electricians are allowed to carry out any work required in the electrical box of this Condair dehumidifier.

When the cover of the electrical box is open, the power supply must be switched off at the mains switch.

Procedure

a) Check the electrical installation before starting the dehumidifier, switch on the mains switch.

- Check the voltage between the terminals L1, L2, L3 (= 400V or 230V for 3 x 230V dehumidifiers)
- Check one of the phases and Neutral (= 230V)
- Is the ground cable connected, and of the correct specifications?
- Is any hygrometer (if fitted) correctly connected?

b) To check the connected duct system

- Is the recommended damper installed in the regeneration air outlet duct (Configuration-A only)
- Is the recommended damper installed in the process air outlet duct (Configuration-A and Configuration-B only)
- Do the regeneration air outlet ducts drain away from the dehumidifier, to make sure that any condensed water flows away?
- If the regeneration air outlet does not drain away from the dehumidifier, check whether there is a 6mm-diameter hole drilled in the lowest part of the duct, so that any accumulated water can drain away.

c) Suggested damper positions/air flow settings at commissioning

Dampers/settings should be set in the following positions.

- Configuration-A:
 - Damper at process air outlet: Fully open.
 - Damper at regeneration air outlet: Fully open.
- Configuration-B:
 - Damper at process air outlet: Fully open.
 - Regeneration air fan speed 80%
- Configuration-C and Configuration-D:
 - Process air fan automatically adjusts to pre-set air flow (no damper needed)
 - Regeneration air fan automatically adjusts to pre-set air flow (no damper needed)

d) If the dehumidifier starts up as described above, then go to e)

If the dehumidifier does not start, you should check the humidity set point (Configuration-B, Configuration-C and Configuration-D only). If set point is higher than measured by the humidity sensor, the dehumidifier will not start (unless the “Always On” program has been chosen – see below).

e) Once the dehumidifier is operating, you should adjust the air flows

Configuration-A:

Adjust the dampers on process air and regeneration air so the incoming air flow matches the nominal values given on page 18. Check the air flows using a suitable instrument (pitot pipe/thermo-anemometer or similar) in the duct.

Configuration-B:

- Adjust the damper on the process air so the incoming air flow matches the nominal value given on page 18. Check the air flow using a suitable instrument (pitot pipe/thermo-anemometer or similar) in the duct.
- Adjust the regeneration air fan speed until the incoming air flow matches the nominal value given on page 18. Check the air flow using a suitable instrument (pitot pipe/thermo-anemometer or similar) in the duct.

Configuration-C and Configuration-D:

- In the Configuration-C and Configuration-D, the dehumidifier is self-adjusting, and adjusts according to default air flows.

SECTION 5 / OPERATION

HOW TO OPERATE THIS DEHUMIDIFIER

The dehumidifier needs to be turned on at the main switch.

After a while the PLC overview screen will appear (Configuration-B, Configuration-C and Configuration-D only).

Diagram view

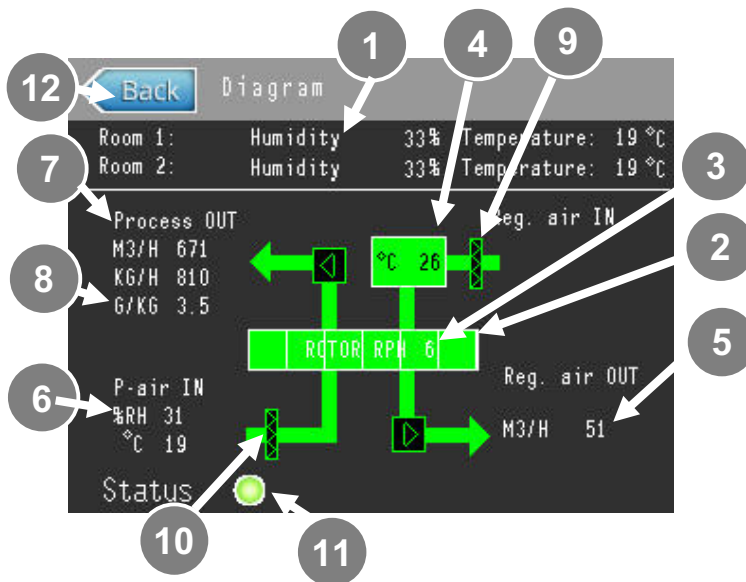

What you see:

1. **Actual measurement for %RH and temperature** within the space concerned (as registered by external sensors not part of the dehumidifier).

In Configuration-B, Configuration-C and Configuration-D, the display can show the dew point of the space concerned, as an alternative measurement.

In Configuration-C and Configuration-D, more sensors can be used to provide measurements of %RH and temperature.

The blue number is the **Target value for %RH** within the space concerned. Pressing the blue number results in a pop-up menu where you can type in a new target value – complete by pressing ENTER.

If you wish to alter the threshold value, you do this on the HUMIDITY/SENSOR1 menu. In Configuration-B, Configuration-C and Configuration-D, you can select dew point instead of %RH – or a combination of these.

2. **Rotor.** If the rotor is turning, this moves. The rotor turns clockwise.
3. **Rotor speed** in rph.
4. **Regeneration air temperature.** Shows the temperature of the heated regeneration air. If the temperature is shown in red, an overheating alarm is triggered.
5. **Regeneration air flow** (Configuration-C and Configuration-D only). The white number indicates the air flow, given by the chosen program. In the CUSTOM program, the regeneration air flow can be manually adjusted in % relation to maximum setting, m³/hour or kg/hour.

In Configuration-B (only) the regeneration air fan can be adjusted in % in relation to maximum setting. This should only be used for initial adjustment, and should not be changed subsequently.
6. **Inflow process air conditions** (Configuration-D only). Actual process air inlet conditions measured in %RH and temperature. This measurement is taken directly after the process air is passing through the process filter.
7. **Adjustment of process flow** (Configuration-C and Configuration-D only). The white number indicates the air flow, given by the chosen program.

In the CUSTOM program, the process air flow can be manually adjusted in % relation to maximum setting, m³/hour or kg/hour.

8. **Adjustment of process air conditions**, measured in g/kg (Configuration-D only). A blue number is visible if you disconnect the external humidify sensor(s). This makes it possible to adjust the process air according to desired g/kg. The blue number is where you adjust the target value. Pressing the blue number results in a pop-up menu where you can type in a new target value – complete by pressing ENTER.
9. **Regeneration air filter** If this is yellow, this filter should soon be replaced. If this is red, the service interval has been exceeded. A mechanical pressure switch triggers a warning (yellow alarm) if the set point is reached. The set point can be manually adjusted at the pressure switches located inside the dehumidifier.
10. **Process air filter** If this is yellow, this filter should soon be replaced. If this is red, the service interval has been exceeded. A mechanical pressure switch triggers a warning (yellow alarm) if the set point is reached. The set point can be manually adjusted at the pressure switches located inside the dehumidifier.
Alarm/warning. Green = everything is OK. Yellow = warning = a service will soon be required (the dehumidifier continue to operate). Red = alarm = there is a fault or malfunction somewhere (the dehumidifier stops immediately). The most likely causes are that the regeneration air heater is over-heating, the filter is blocked, or the service interval has been exceeded.
11. **Actual mode.** Indication of chosen program. See more information on page 54.
12. **Return to main menu**

Note that if you attempt to change values, you will be asked to enter an operator code (1234 is standard/default).

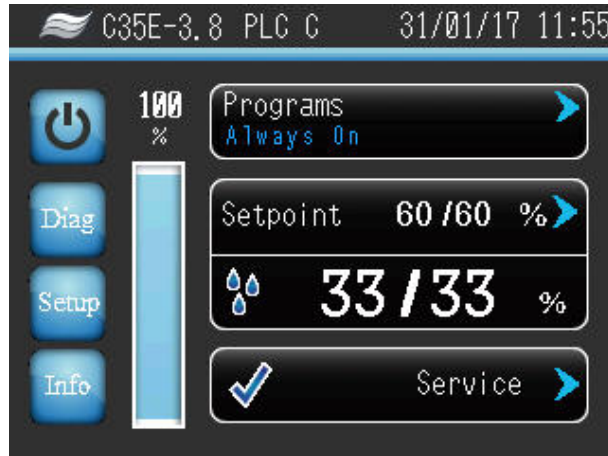
MAIN menu**What you see:**

START/STOP Turn the dehumidifier on and off.

HUMIDITY menu. This is where you decide the levels of humidity that the dehumidifier provides.

PROGRAMS menu. This is where you decide how you want the dehumidifier to operate (Always On, RH On/Off, Capacity Control (Configuration-B only), Energy, Quiet, or Custom programs (Configuration-C and Configuration-D only), and Energy+ (Configuration-D only).

SERVICE menu. This is where you can see the status of service, and also where you reset the timer after a time-expired component has been replaced. Green = everything is OK. Yellow = service is needed (the dehumidifier continue to operate). Red = critical alarm and service is needed immediately (the dehumidifier stops operating).

By pressing the **Diag** icon, you will switch to the diagram view, as seen on page 44.

SETUP menu. This is where you set the date and time, language setting and login menu. An advanced menu and timer function are also available.

Info: This is where you can read product details such as dehumidifier type, serial number, build date, software revision and running hours. Contact information is also available for you to enter (customer and dealer information). A performance log is available with indications of %RH and dew point. The performance log registers data every hour.

The **blue bar** displays the current power-utilisation of the regeneration heating. The capacity of the dehumidifier is adjusted by modulating the temperature of the regeneration heating.

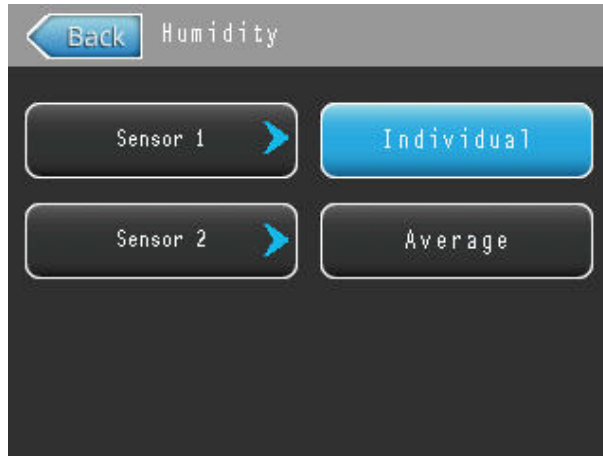
HUMIDITY menu**What you see:**

SENSOR 1. This button is only shown when a sensor is connected. Pressing this button leads to a pop-up menu where you can adjust the humidity target values for that particular sensor.

SENSOR 2 (Configuration-C and Configuration-D only). This button is only shown when a sensor is connected. Pressing this button leads to a pop-up menu where you can adjust the humidity target values for that particular sensor.

PROCESS AIR HUMIDITY (Configuration-D only). Pressing this button leads to a pop-up menu where you can adjust the humidity target values (g/kg) for the process air leaving the dehumidifier. This button is only visible if there is no SENSOR 1 and/or SENSOR 2 connected.

INDIVIDUAL and **AVERAGE** buttons are only visible if both SENSOR 1 and SENSOR 2 are connected. The standard setting is INDIVIDUAL.

INDIVIDUAL means that the dehumidifier is controlled by the value measured by each individual sensor. If the air humidity level increases above the threshold value set for one of the sensors, the dehumidifier starts running.

If you press AVERAGE, it means that the dehumidifier is controlled by the average of the values measured by each individual sensor, in relation to the designated threshold values. If the average values actually measured fall below the threshold values, the dehumidifier starts running. The designated threshold values defined in the SENSOR 1 menu are copied to the SENSOR 2 menu, which means that it is only possible to adjust the overall average values by adjusting the values in the SENSOR 1 menu.

This is important in cases where (for example) one of the sensors takes measurements near a door or other entry point into the building, and where the level of humidity can go up for a short while, without this necessarily representing a problem.

So, in AVERAGE, the target values for the sensors are identical.

Return to main menu

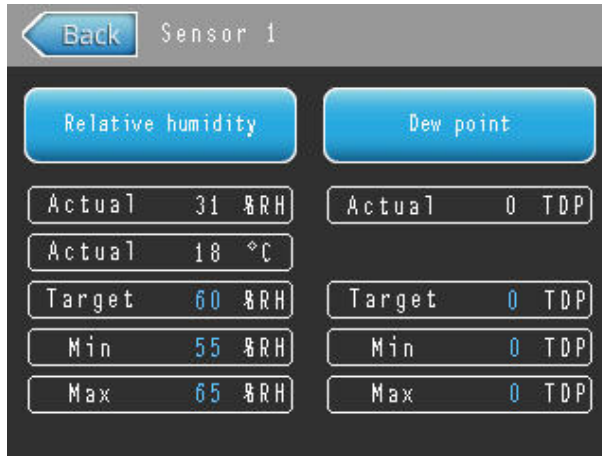
HUMIDITY / SENSOR 1 menu**What you see:**

ACTUAL values measured by sensor 1 Measures both %RH and °C. Dew point measurement is available in Configuration-B, Configuration-C and Configuration-D.

Controlling RELATIVE HUMIDITY with the dehumidifier. Pressing the RELATIVE HUMIDITY checkbox at the top makes the dehumidifier control relative humidity as measured by the sensor (default setting).

TARGET value can be changed by pressing the blue number. A keyboard then pops up where you can type in a desired value. MAX and MIN values automatically change in ± 5 increments in relation to the entered target value. You should adjust the TARGET value first, followed by the MAX and MIN values afterwards.

Threshold values (MIN and MAX) The MIN and MAX values can be changed the same way, by pressing the blue numbers. Threshold values define the hysteresis for RH On/Off, Constant Process Air, Energy, Quiet and Custom programs. When the actual %RH measured by the external sensor exceeds the MAX value (+1 %), the dehumidifier starts. When the %RH measured by the external sensor is below the MIN value (-1 %), the dehumidifier stops.

If the Capacity Control program is selected (Configuration-B only), the TARGET and MIN values are the only ones shown. Here the target value is the desired target value that the dehumidifier must reach. The dehumidifier stops when the actual %RH is below the MIN value. If the dehumidifier must be kept operating at all times, the MIN value is set to (for example) 1%RH. If the relative humidity falls dramatically and the heating is not active for 1 minute, the regeneration air will shut down (when the temperature in the heating box falls below 60°C) and enable constant process air ventilation.

The MIN value defines when the dehumidifier is turned off (-1% below MIN) in the Energy, Quiet and Custom programs (only for Configuration-C and Configuration-D). See page 54 for more information.

Controlling DEW POINT with the dehumidifier The MIN and MAX values can be changed the same way, by pressing the blue numbers. Threshold values define the hysteresis for RH On/Off, Energy, Quiet and Custom programs. When the actual dew point measured by the external sensor exceeds the MAX value (+1 TDP), the dehumidifier starts. When the dew point measured by the external sensor is below the MIN value (-1 TDP), the dehumidifier stops.

If the Capacity Control program is selected (Configuration-B only), the TARGET and MIN values are the only ones shown. Here the target value is the desired target value that the dehumidifier must reach. The dehumidifier stops when the actual dew point is below the MIN value (-1 TDP). If the dehumidifier must be kept operating at all times, the MIN value is set to (for example) -6 dew point. If the dew point falls dramatically and the heating is not active for 1 minute, the regeneration air will shut down (when the temperature in the heating box falls below 60°C) and enable constant process air ventilation.

The MIN value defines when the dehumidifier is turned off in Energy, Quiet and Custom programs (only for Configuration-C and Configuration-D). See page 54 for more information.

Controlling both RELATIVE HUMIDITY and DEW POINT with the dehumidifier: If required, you can control the dehumidifier on the basis of both %RH and dew point measurements at the same time. In such cases, both checkboxes should be marked.

Return to main menu

Return to HUMIDITY menu

HUMIDITY / SENSOR 2 menu

(Configuration-C and Configuration-D only)



What you see:

ACTUAL values measured by SENSOR 2 Measures both %RH and °C. Dew point measurement is available in Configuration-C and Configuration-D for sensor 2.

Controlling RELATIVE HUMIDITY with the dehumidifier. Pressing the RELATIVE HUMIDITY checkbox at the top makes the dehumidifier control relative humidity, as measured by the sensor (default setting).

TARGET value can be changed by pressing the blue number. A keyboard then pops up where you can enter a desired value. The MAX and MIN values automatically change in ± 5 increments in relation to the entered target value. You should adjust the TARGET value first, followed by the MAX and MIN values afterwards.

Threshold values (MIN and MAX) The MIN and MAX values can be changed the same way, by pressing the blue numbers. Threshold values define the hysteresis for RH On/Off, Constant Process Air, Energy, Quiet and Custom programs. When the actual %RH measured by the external sensor exceeds the MAX value (+1%), the dehumidifier starts. When the %RH measured by the external sensor is below the MIN value (-1%), the dehumidifier stops.

If the Capacity Control program is selected (Configuration-B only), the TARGET and MIN values are the only ones shown. Here the target value is the desired target value that the dehumidifier must reach. The dehumidifier stops when the actual %RH is below the MIN value (-1% of MIN). If the dehumidifier must be kept operating at all times, the MIN value is set to (for example) 1%RH. If the relative humidity falls dramatically and the heating is not active for 1 minute, the regeneration air will shut down (when the temperature in the heating box falls below 60°C) and enable constant process air ventilation.

The MIN value defines when the dehumidifier is turned off (-1% below MIN) in the Energy, Quiet and Custom programs (only for Configuration-C and Configuration-D). See page 54 for more information.

Controlling DEW POINT with the dehumidifier The MIN and MAX values can be changed the same way, by pressing the blue numbers. Threshold values define the hysteresis for RH On/Off, Energy, Quiet and Custom programs. When the actual dew point measured by the external sensor exceeds the MAX value (+1 TDP), the dehumidifier starts. When the dew point measured by the external sensor is below the MIN value (-1 TDP), the dehumidifier stops.

If the Capacity Control program is selected (Configuration-B only), the TARGET and MIN values are the only ones shown. Here the target value is the desired target value that the dehumidifier must reach. The dehumidifier stops when the actual dew point is below the MIN value. If the dehumidifier must be kept operating at all times, the MIN value is set to (for example) -6 in dew point. If the dew point falls dramatically and the heating is not active for 1 minute, the regeneration air will shut down (when the temperature in the heating box falls below 60°C) and enable constant process air ventilation.

The MIN value defines when the dehumidifier is turned off in the Energy, Quiet and Custom programs (only for Configuration-C and Configuration-D). See page 54 for more information.

Controlling both RELATIVE HUMIDITY and DEW POINT with the dehumidifier: If required, you can control the dehumidifier on the basis of both %RH and dew point measurements at the same time. In such cases, both checkboxes should be marked.

Return to main menu

Return to HUMIDITY menu

PROCESS AIR HUMIDITY

(Configuration-D only, and only when no external sensors are mounted)

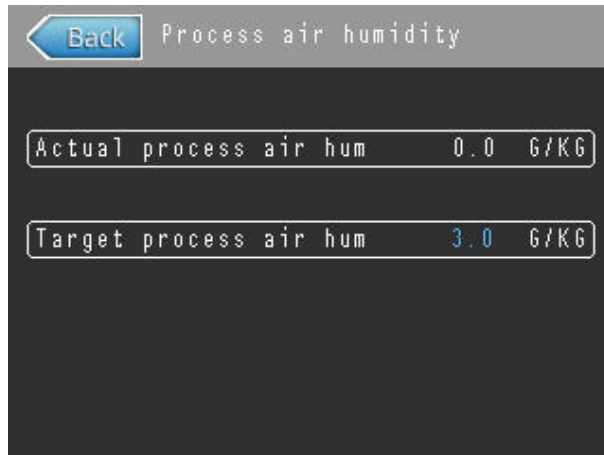

What you see:

- 1) **Actual PROCESS AIR HUMIDITY (g/kg)**
- 2) **Target PROCESS AIR HUMIDITY (g/kg)**

There are no threshold values shown because the dehumidifier is running all the time, and does not make adjustments in relation to threshold values.

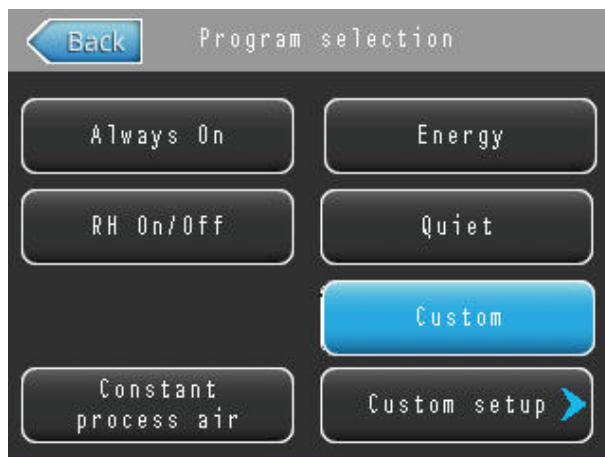
PROGRAMS menu (when at least SENSOR 1 is attached)**What you see:**

ALWAYS ON The dehumidifier is running at full power all the time.

RH ON/OFF The dehumidifier is controlled by an external sensor. When the values measured by this sensor are below the MIN value you have set, the dehumidifier is turned off. When the values measured by this sensor are above the MAX value you have set, the dehumidifier is turned on, and running at full power. See more details of targets and threshold on page 49 and 51.

CONSTANT PROCESS AIR The main purpose is to enable air circulation even though dehumidification is not required. The CONSTANT PROCESS AIR selection is not a standalone program and is only operating in collaboration with another program selection. If RH ON/OFF program is chosen and the dehumidifier stops operating due to achieved humidity levels – the process fan continue to operate when the CONSTANT PROCESS AIR selection is enabled.

CAPACITY CONTROL (Configuration-B only). The focus here is on removing unwanted humidity, so the fans are running at all times if the MIN value is set to (for example) 1%RH. When the values measured by this sensor are below the MIN value you have set, the dehumidifier is turned off. The heating increases slowly in order to carry out dehumidification according to capacity needed. If the TARGET value is lower than actual %RH measured by the external sensor, the dehumidifier's heating capacity will be fully activated within approximately 10–15 minutes (100% heating capacity). When the actual %RH is within the TARGET value, the heating capacity is automatically adjusted to meet requirements. For detailed instructions about how to set up target values in the Capacity Control program, see page 49.

ENERGY (Configuration-C only). In addition to removing unwanted humidity, the focus here is on removing such humidity in a more energy-efficient manner. When turned on, the speed of the rotor and the level of heat are adjusted to meet requirements and to save energy.

The dehumidifier is turned off when the values measured by the sensor(s) are below the threshold MIN value you have set. See page 49 and 51 for more details.

ENERGY+ (Configuration-D only). The focus here is on removing unwanted humidity and keeping overall energy consumption to a minimum. In the program used in the Configuration-D, the flow of air, the level of heat and the rotation of the humidity-absorbing rotor are all controlled by measurements made by high-precision internal sensors.

The dehumidifier is turned off when the values measured by the sensor(s) are below the threshold MIN value you have set. See page 49 and 51 for more details.

QUIET (Configuration-C and Configuration-D only). The focus here is on making sure the dehumidifier runs as quietly as possible. The dehumidifier is only turned on when the values measured by an external sensor are above the target you have set.

In this configuration, all the air flows are reduced as much as possible, in order to keep noise levels to a minimum.

The dehumidifier is turned off when the values measured by the sensor(s) are below the threshold MIN value you have set. See page 49 and 51 for more details.

CUSTOM SETUP (Configuration-C and Configuration-D only). In this configuration, you can adjust all the values individually, within predefined limits. See page 58 for more details.

The dehumidifier is turned off when the values measured by the sensor(s) are below the threshold MIN value you have set. See page 49 and 51 for more details.

Return to main menu

PROGRAMS menu in PROCESS mode

(for Configuration-D when no external sensors are attached)



What you see:

ALWAYS ON The dehumidifier is running at full power all the time.

ENERGY+ The focus here is on keeping a target absolute humidity (g/kg), as defined in the humidity menu. The target process air flow (kg/hour) can be specified by pressing the ENERGY+ SETUP button. See page 57 for more details.

In ENERGY+, the flow of air, the level of heat and the rotation of the humidity-absorbing rotor are all controlled by measurements made by high-precision internal sensors.

CUSTOM SETUP. In this configuration, you can adjust all the values individually, within predefined limits. See page 58 for more details.

Return to main menu

PROGRAMS / PROCESS MODE / PROCESS FLOW

(For Configuration-D when no external sensors are attached)

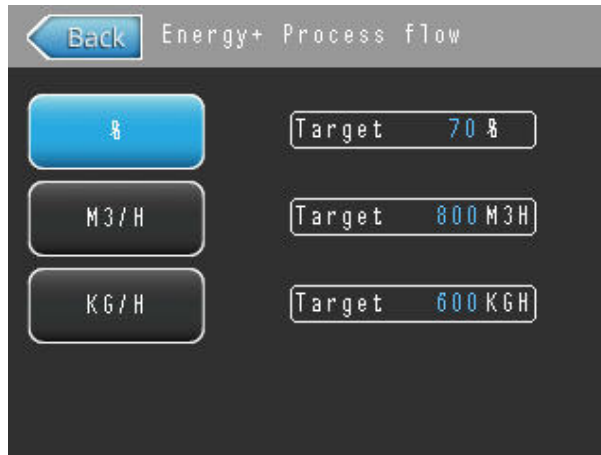

What you see:

% in relation to maximum fan speed

m³/hour**kg/hour****Return to main menu**To **PROGRAMS** menu

The setting you have selected appears in blue.

The values in this setting remain constant while the dehumidifier is running, but the other values can change.

You change the values by pressing on the blue number, and you change the function by pressing anywhere else on the button.

NOTE

You should only change the process air flow if you are familiar with the effect of the different parameters and know what you are doing.

If the settings are incorrect or ill-advised, this can have substantial effects on your installations or processes, and may even damage the dehumidifier.

Condair cannot take responsibility for any changes you make in the standard programs, or for the results of any such changes.

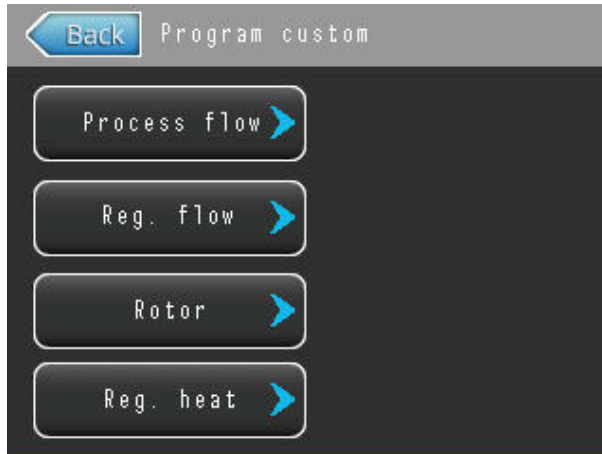

PROGRAM / CUSTOM**What you see:**

Adjustment of process flow (Configuration-C and Configuration-D only)

Adjustment of regeneration air flow (Configuration-B, Configuration-C and Configuration-D only)

Adjustment of rotor speed (Configuration-C and Configuration-D only)

Adjustment of levels of heat in regeneration air flow (Configuration-C and Configuration-D only)

Return to main menu

Return to PROGRAMS menu

**NOTE**

You should only use the CUSTOM menu to make changes to the operating settings if you are familiar with the effect of the different parameters and know what you are doing.

If the settings are incorrect or ill-advised, this can have substantial effects on your installations or processes, and may even damage the dehumidifier.

Condair cannot take responsibility for any changes you make in the standard programs, or for the results of any such changes.

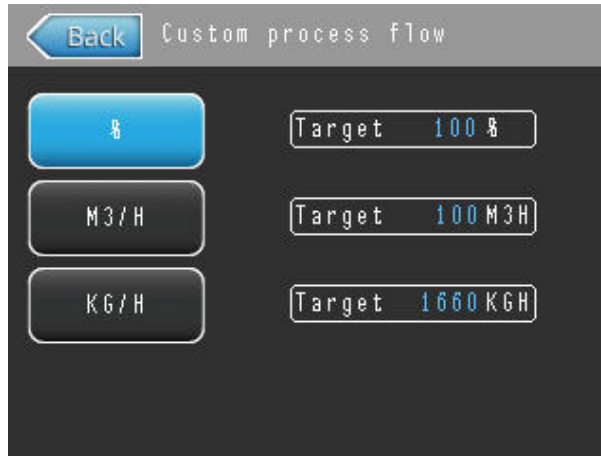
PROGRAMS / CUSTOM / PROCESS FLOW**What you see:**

% in relation to maximum fan speed (Configuration-C and Configuration-D only)

m³/hour (Configuration-C and Configuration-D only)

kg/hour (Configuration-C and Configuration-D only)

Return to main menu

To **CUSTOM** menu

The setting you have selected appears in blue.

The values in this setting remain constant while the dehumidifier is running, but the other values can change.

You change the values by pressing on the blue number, and you change the function by pressing anywhere else on the button.

In the CUSTOM program the dehumidifier is turned off when the values measured by the sensor(s) are below the threshold MIN value you have set. See page 49 and 51 for more details.

NOTE

You should only change the process air flow if you are familiar with the effect of the different parameters and know what you are doing.

If the settings are incorrect or ill-advised, this can have substantial effects on your installations or processes, and may even damage the dehumidifier.

Condair cannot take responsibility for any changes you make in the standard programs, or for the results of any such changes.

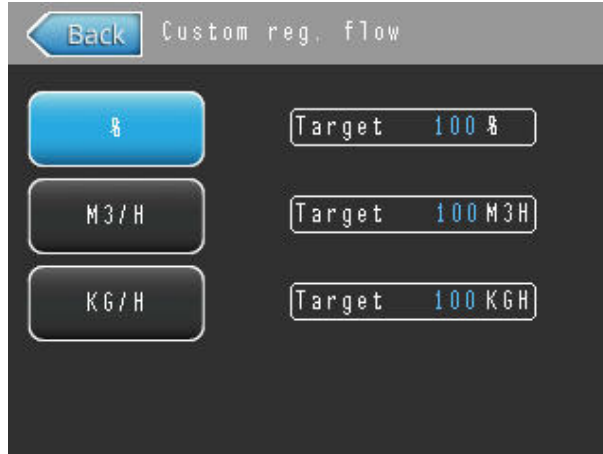

PROGRAMS / CUSTOM / REG FLOW**What you see:**

% in relation to maximum fan speed (Configuration-C and Configuration-D only)

m³/hour (Configuration-C and Configuration-D only) (based on normal m³ [20°C])

kg/hour (Configuration-C and Configuration-D only)

Return to main menu

The setting you have selected appears in blue.

The values in this setting remain constant while the dehumidifier is running, but the other values can change.

You change the values by pressing on the blue number, and you change the function by pressing anywhere else on the button.

In the CUSTOM program the dehumidifier is turned off when the values measured by the sensor(s) are below the threshold MIN value you have set. See page 49 and 51 for more details.

NOTE

You should only change the regeneration air flow if you are familiar with the effect of the different parameters and know what you are doing.

If the settings are incorrect or ill-advised, this can have substantial effects on your installations or processes, and may even damage the dehumidifier.

Condair cannot take responsibility for any changes you make in the standard programs, or for the results of any such changes.

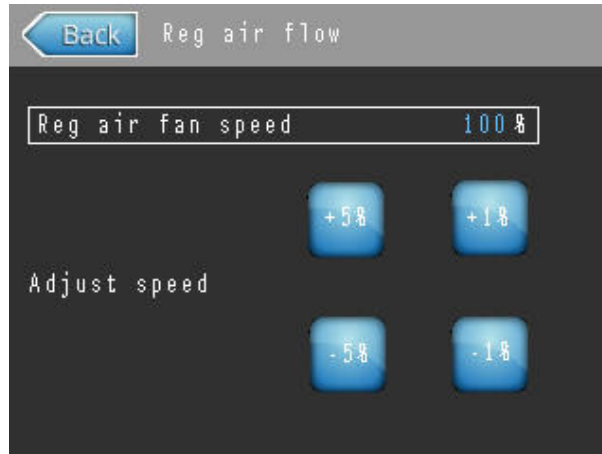

PROGRAMS / CUSTOM / REG AIR FLOW

You can reach this screen in two different ways:

- Choose % fan speed figure on the CUSTOM REG AIR menu
- Choose the blue % fan speed figure in the OVERVIEW menu (Configuration-B only)

You use it to adjust the fan that delivers the regeneration air that dries the rotor.

If, for example, you wish to achieve a value of 200 m³/hour, you place a flow measuring device in the duct and press the setting figure until it corresponds with a 200 m³/hour flow.

In the CUSTOM program the dehumidifier is turned off when the values measured by the sensor(s) are below the threshold MIN value you have set. See page 49 and 51 for more details.

NOTE

You should only use the CUSTOM menu to make changes to the operating settings if you are familiar with the effect of the different parameters and know what you are doing.

If the settings are incorrect or ill-advised, this can have substantial effects on your installations or processes, and may even damage the dehumidifier.

Condair cannot take responsibility for any changes you make in the standard programs, or for the results of any such changes.

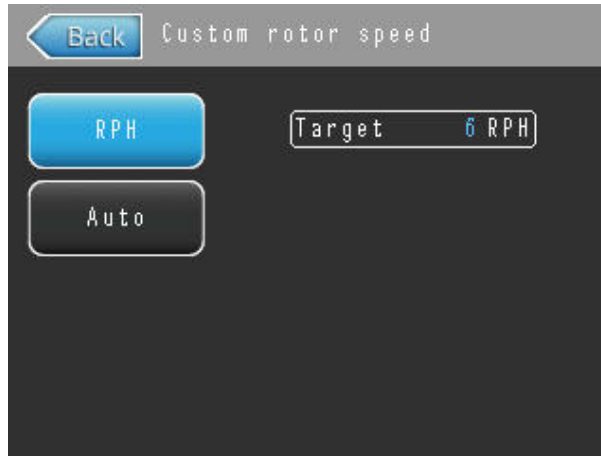

PROGRAMS / CUSTOM / ROTOR**What you see:**

RPH – this is where you select rotor speed (Configuration-C and Configuration-D only), by pressing the blue number, and entering the new value.

AUTO – automatically calculates the ideal rotor speed (rph).

The rotor always turns clockwise. Check the rotation of the rotor when installing the dehumidifier.

Return to main menu

In the CUSTOM program the dehumidifier is turned off when the values measured by the sensor(s) are below the threshold MIN value you have set. See page 49 and 51 for more details.

NOTE

You should only change rotor speed if you are familiar with the effect of the different parameters and know what you are doing.

If the settings are incorrect or ill-advised, this can have substantial effects on your installations or processes, and may even damage the dehumidifier.

Condair cannot take responsibility for any changes you make in the standard programs, or for the results of any such changes.

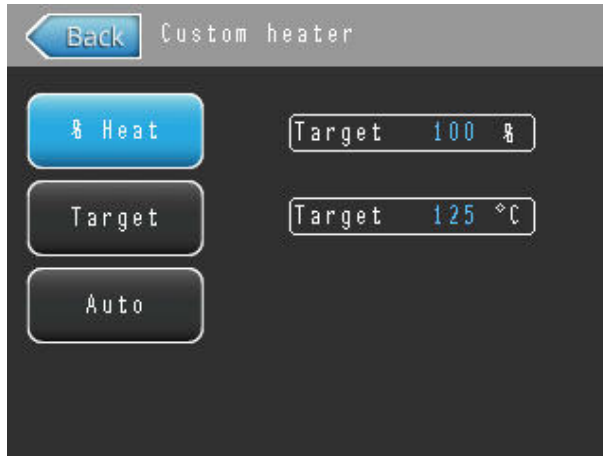

PROGRAMS / CUSTOM / HEAT**What you see:**

% HEAT Select heat setting as % of maximum possible heat effect.

TARGET Select desired temperature (fixed temperature). NB you may not be able to achieve the desired temperature, because this can depend on air conditions outside. However, the dehumidifier will use this value as a target that it will attempt to achieve.

AUTO Automatically calculates the ideal level of heat in relation to the setting for regeneration air flow.

Return to main menu

In the CUSTOM program the dehumidifier is turned off when the values measured by the sensor(s) are below the threshold MIN value you have set. See page 49 and 51 for more details.

NOTE

You should only change the heater temperature if you are familiar with the effect of the different parameters and know what you are doing.

If the settings are incorrect or ill-advised, this can have substantial effects on your installations or processes, and may even damage the dehumidifier.

Condair cannot take responsibility for any changes you make in the standard programs, or for the results of any such changes.

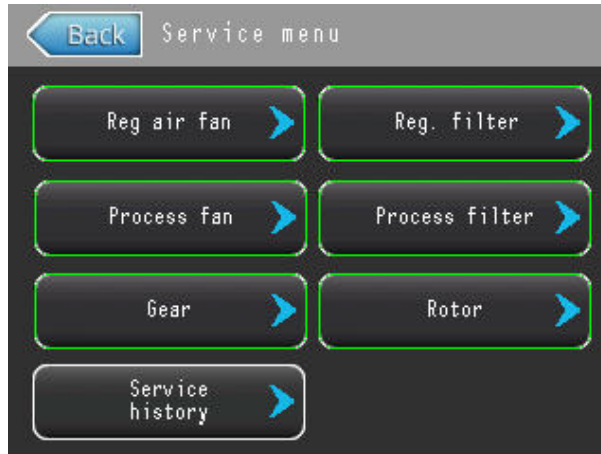

SERVICE menu

What you see:

REG AIR FAN

PROCESS FAN

GEAR

REG FILTER

PROCESS FILTER

ROTOR

SERVICE HISTORY

Return to main menu

What the colours mean (on the SERVICE menu)

If your Condair dehumidifier is operating perfectly, the frame surrounding each button will be **green**.

If a particular component in your Condair dehumidifier is approaching the end of its planned service life, the frame surrounding the particular button will be **yellow** (a warning indication).

If a particular component in your Condair dehumidifier has exceeded its planned service life and now needs replacing, the frame surrounding the particular button will be **red**.

The filters and rotors are fitted with mechanical alarms that provide information on the display if any kind of service is due.

If a particular component in your Condair dehumidifier has stopped operating correctly, resulting in a critical alarm, the frame surrounding the particular button will be **red** (indicating a critical alarm that stops the dehumidifier completely).

SERVICE / REGENERATION AIR FAN**What you see:**

REMAINING LIFE = Estimated service life left for the component or group of components.

ORDER to get details about how to order spare parts. When you press the ORDER button, you get the appropriate part number, and details of where to contact your Condair.

REPLACE (and reset actual service hours counter). Press the REPLACE button followed by the blue number in Set New Time. Set a new time, based on the estimated service life left for the component. A list of the remaining service lives is shown on page 101. Press the REPLACE button to update the timer.

When you press the REPLACE button, you will be asked to enter an operator code (1234 is standard/default).

Return to main menu

Return to SERVICE



Back Order reg. air fan

Part No: 801668
RH22V

Dealer:

Cotes: 0045 58196322

When you have pressed the ORDER button, you will see ordering details.



Back Replace reg. air fan

Replaced

set new time 30000 Hours

When you have pressed the REPLACE button and entered the appropriate operator code, you will see the screen shown above.

This is where you reset the remaining service life for the component, using a drop-down keyboard.

SERVICE / PROCESS AIR FAN

What you see:

REMAINING LIFE = Estimated service life left for the component or group of components.

ORDER to get details about how to order spare parts. When you press the ORDER button, you get the appropriate part number, and details of where to contact your Condair.

REPLACE (and reset the actual service hours counter). Press the REPLACE button followed by the blue number in Set New Time. Set a new time based on the estimated service life left for the component. A list of the remaining service lives is shown on page 101. Press the REPLACE button to update the timer.

When you press the REPLACE button, you will be asked to enter an operator code (1234 is standard/default).

Return to main menu

Return to SERVICE



Back Order process air fan

Part No: 801667
RH25C

Dealer:

Cotes: 0045 58196322

When you have pressed the ORDER button, you will see ordering details.



Back Replace process air fan

Replaced

set new time 40000 Hours

When you have pressed the REPLACE button and entered the appropriate operator code, you will see the screen shown above.

This is where you reset the remaining service life for the component, using a drop-down keyboard.

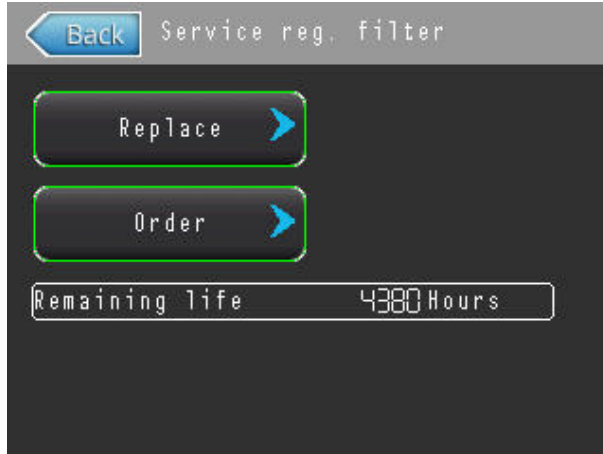
SERVICE / REGENERATION AIR FILTER

What you see:

REMAINING LIFE = Estimated service life left for the component or group of components.

ORDER to get details about how to order spare parts. When you press the ORDER button, you get the appropriate part number, and details of where to contact your Condair.

REPLACE (and reset the actual service hours counter). Press the REPLACE button followed by the blue number in Set New Time. Set a new time based on the estimated service life left for the component. A list of the remaining service lives is shown on page 101. Press the REPLACE button to update the timer.

When you press the REPLACE button, you will be asked to enter an operator code (1234 is standard/default).

Return to main menu

Return to SERVICE

Back Order reg. filter

Part No: FILTER 130363
200X200X48 G4 GALV F.

Dealer:

Cotes: 0045 58196322

When you have pressed the ORDER button, you will see ordering details.

Back Replace reg. filter

Replaced

set new time 4380 Hours

When you have pressed the REPLACE button and entered the appropriate operator code, you will see the screen shown above.

This is where you reset the remaining service life for the component, using a drop-down keyboard.

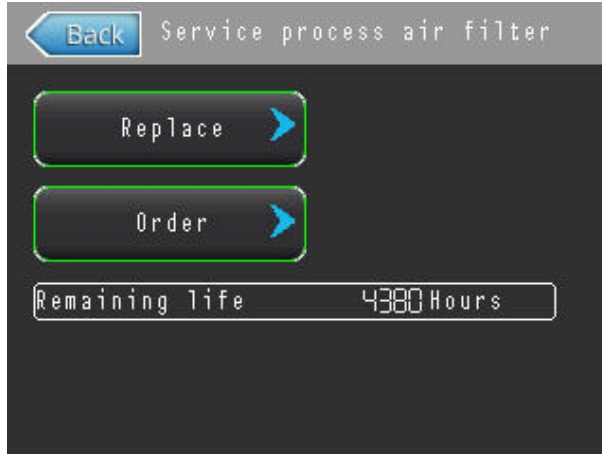
SERVICE / PROCESS AIR FILTER

What you see:

REMAINING LIFE = Estimated service life left for the component or group of components.

ORDER to get details about how to order spare parts. When you press the ORDER button, you get the appropriate part number, and details of where to contact your Condair.

REPLACE (and reset the actual service hours counter). Press the REPLACE button followed by the blue number in Set New Time. Set a new time based on the estimated service life left for the component. A list of the remaining service lives is shown on page 101. Press the REPLACE button to update the timer.

When you press the REPLACE button, you will be asked to enter an operator code (1234 is standard/default).

Return to main menu

Return to SERVICE

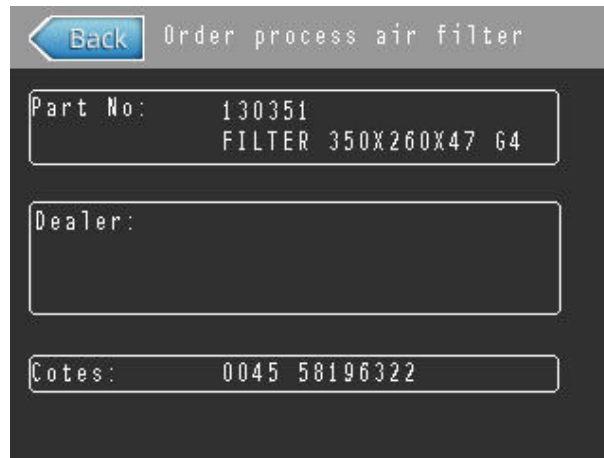

When you have pressed the ORDER button, you will see ordering details.

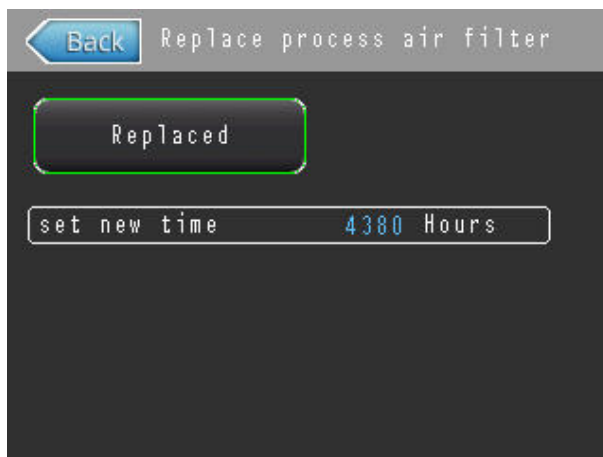

When you have pressed the REPLACE button and entered the appropriate operator code, you will see the screen shown above.

This is where you reset the remaining service life for the component, using a drop-down keyboard.

SERVICE / GEAR

What you see:

REMAINING LIFE = Estimated service life left for the component or group of components.

ORDER to get details about how to order spare parts. When you press the ORDER button, you get the appropriate part number, and details of where to contact your Condair.

REPLACE (and reset the actual service hours counter). Press the REPLACE button followed by the blue number in Set New Time. Set a new time based on the estimated service life left for the component. A list of the remaining service lives is shown on page 101. Press the REPLACE button to update the timer

When you press the REPLACE button, you will be asked to enter an operator code (1234 is standard/default).

Return to main menu

Return to SERVICE

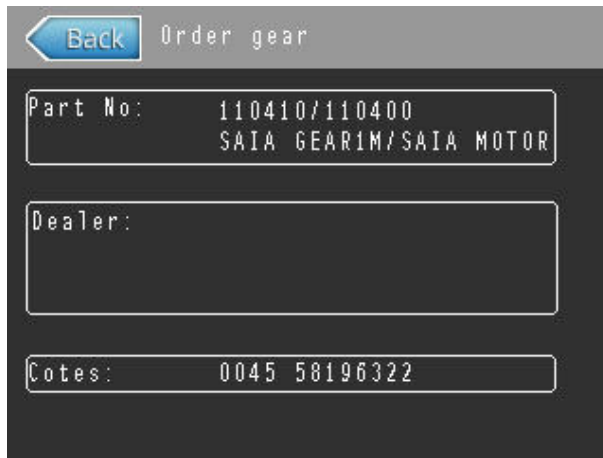

When you have pressed the ORDER button, you will see ordering details.

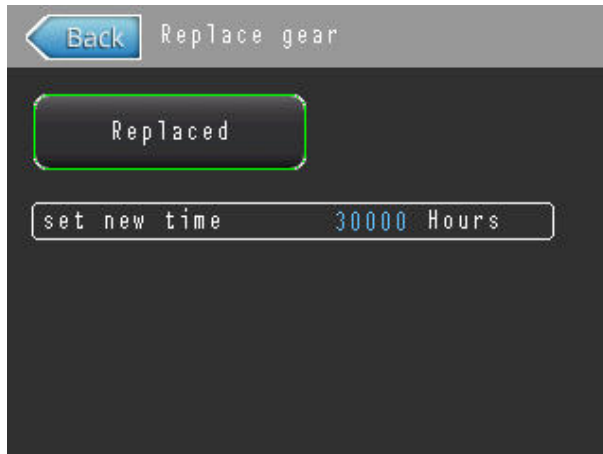

When you have pressed the REPLACE button and entered the appropriate operator code, you will see the screen shown above.

This is where you reset the remaining service life for the component, using a drop-down keyboard.

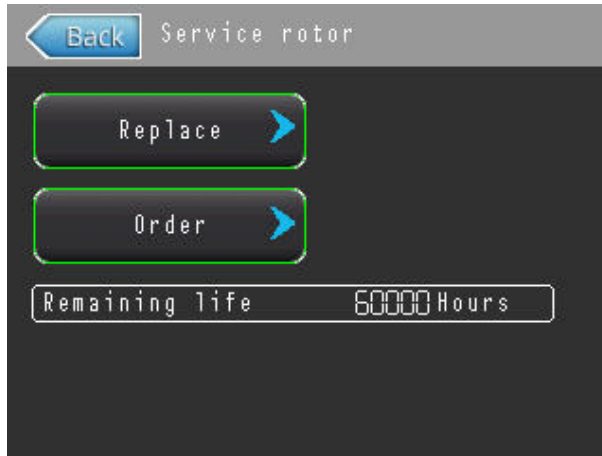
SERVICE / Rotor

What you see:

REMAINING LIFE = Estimated service life left for the component or group of components.

ORDER to get details about how to order spare parts. When you press the ORDER button, you get the appropriate part number, and details of where to contact your Condair.

REPLACE (and reset the actual service hours counter). Press the REPLACE button followed by the blue number in Set New Time. Set a new time based on the estimated service life left for the component. A list of the remaining service lives is shown on page 101. Press the REPLACE button to update the timer.

When you press the REPLACE button, you will be asked to enter an operator code (1234 is standard/default).

Return to main menu

Return to SERVICE

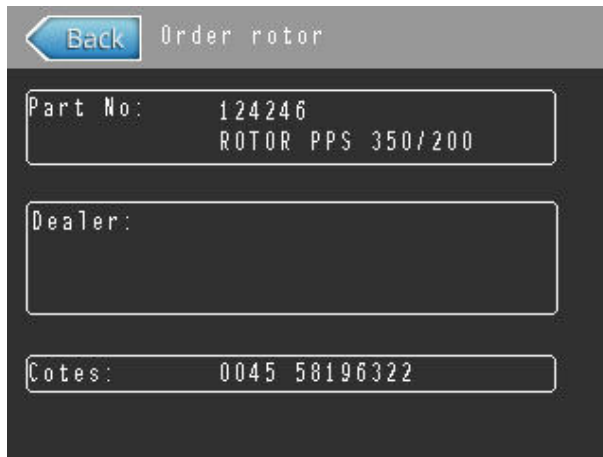

Back Order rotor

Part No: 124246
ROTOR PPS 350/200

Dealer:

Cotes: 0045 58196322

When you have pressed the ORDER button, you will see ordering details.

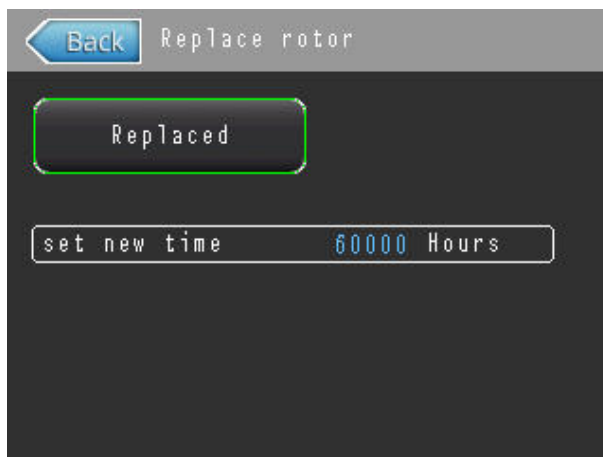

Back Replace rotor

Replaced

set new time 60000 Hours

When you have pressed the REPLACE button and entered the appropriate operator code, you will see the screen shown above.

This is where you reset the remaining service life for the component, using a drop-down keyboard.

ALARM

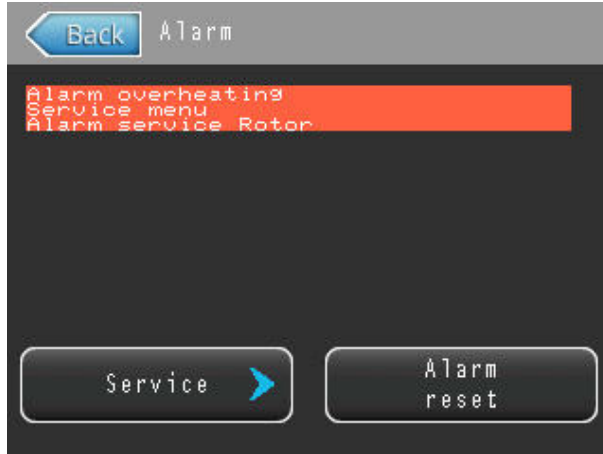

This is where you can see any alarms relevant to the operation of your Condair dehumidifier.

What you see:

INFORMATION ALARMS These are solely for your information, and you do not have to do anything. Example: “out of reach”.

After you have read the information, you can delete the alarm by pressing ALARM RESET.

REPLACE ALARMS These tell you that a particular component will soon exceed, or has exceeded, its service life and must be replaced.

All alarms are shown. When you press ALARM RESET, all information alarms disappear.

NB: The safety thermostat will appear as an alarm if the temperature in the heating box around the filter exceeds 176 °C. If this happens, you will have to reset this alarm manually.

This is done by pressing the release button on the safety thermostat located on the cable tray on the back of the dehumidifier. This is why you cannot reset the alarm on the PLC itself – it can only be done after it has been done on the actual thermostat.

You should also check the condition of the regeneration air filter if an overheating alarm has been triggered.

SETUP menu

What you see:

DATE AND TIME – this is where you adjust the date and time, if necessary.

TIMER – this is where you adjust the timer setting.

ADVANCED – this is where you enter the height above mean sea level, and the regeneration air fan (Configuration-B only).

LANGUAGE – you can choose between English, German, French and Danish.

LOGIN – this is where you can log in to change settings.

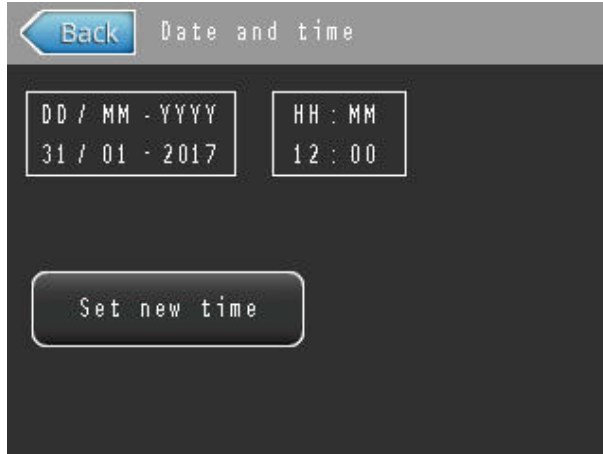
SET / DATE / TIME**What you see:**

You see actual settings of date and time. If you want to change these, press SET NEW TIME.

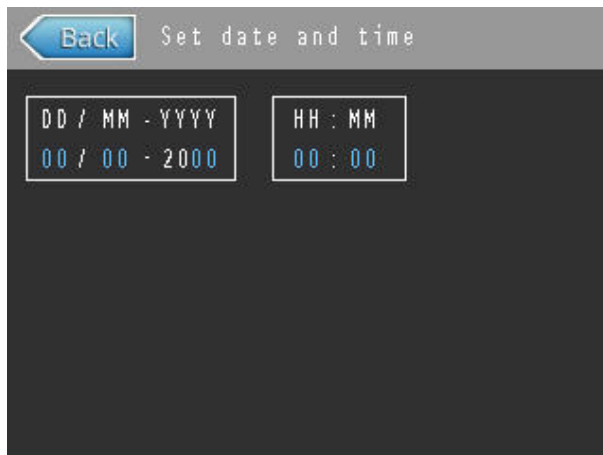

When you press on any blue number, a drop-down keyboard appears. Enter a new value, and complete the operation by pressing ENTER.

SET / TIMER

What you see:

TIMER PROGRAM – this is where you select which program is to run when the timer is on. Pressing on this button brings up the **TIMER PROGRAM MENU**. You can see the chosen timer program in the upper right corner. The timer function is available in Configuration-B, Configuration-C and Configuration-D.

TIMER HUMIDITY – this is where you define the targets when the timer is on.

DAY/NIGHT TIMER – this is the day and night timer function. It works by using an internal clock, meaning that the **START** is set to (for example) 7 and the **END** is set to (for example) 16 (using the 24-hour clock). It will now start the selected **TIMER PROGRAM** at 7.00 and stop it at 16.00.

CYCLE TIMER – this is the cycle timer, which operates in working minutes (1 minute as minimum and 10080 minutes as maximum, corresponding to 1 week). As with the **DAY/NIGHT TIMER**, a **TIMER PROGRAM** is selected in which the **CYCLE TIMER** continues to switch between programs when the defined cycle has ended.

START – this is where you select when the timer starts running (**DAY/NIGHT TIMER** only).

END – this is where you select when the timer stops running (**DAY/NIGHT TIMER** only).

NORMAL – this is the normal (standard) selected program set point, in minutes (**CYCLE TIMER** only).

TIMER – this is the timer selected program set point, in minutes (**CYCLE TIMER** only).

START TIMER – this is where you start the timer function.

STOP TIMER – this is where you stop the timer function.

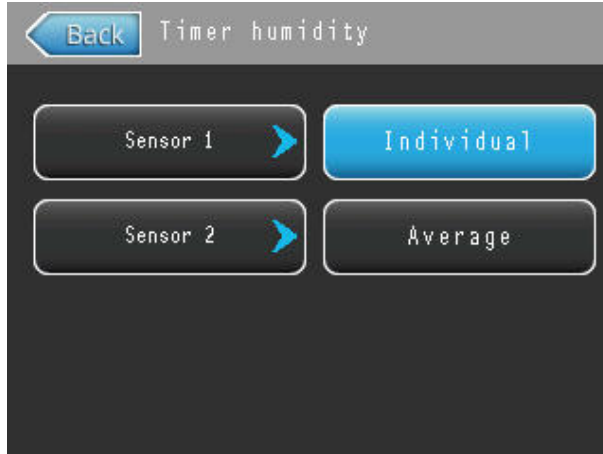
SET / TIMER / HUMIDITY

What you see:

SENSOR 1. This button is only shown when a sensor is connected. Pressing this button leads to a pop-up menu where you can adjust the humidity target values for that particular sensor.

SENSOR 2 (Configuration-C and Configuration-D only). This button is only shown when a second sensor is connected. Pressing this button leads to a pop-up menu where you can adjust the humidity target values for that particular sensor.

PROCESS AIR HUMIDITY (Configuration-D only). Pressing this button leads to a pop-up menu where you can adjust the humidity target values (g/kg) for the process air leaving the dehumidifier. This button is only visible if there is no SENSOR 1 and/or SENSOR 2 connected.

INDIVIDUAL and **AVERAGE** buttons are only visible if both SENSOR 1 and SENSOR 2 are connected. The standard setting is INDIVIDUAL.

INDIVIDUAL means that the dehumidifier is controlled by the value measured by each individual sensor. If the air humidity level increases above the threshold value set for one of the sensors, the dehumidifier starts running.

If you press AVERAGE, it means that the dehumidifier is controlled by the average of the values measured by each individual sensor, in relation to the designated threshold values. If the average values actually measured fall below the threshold values, the dehumidifier starts running.

This is important in cases where (for example) one of the sensors takes measurements near a door or other entry point into the building, and where the level of humidity can go up for a short while, without this necessarily representing a problem.

In AVERAGE, the TARGETS values for the sensors must be identical.

Return to main menu

SET / TIMER / HUMIDITY / SENSOR1

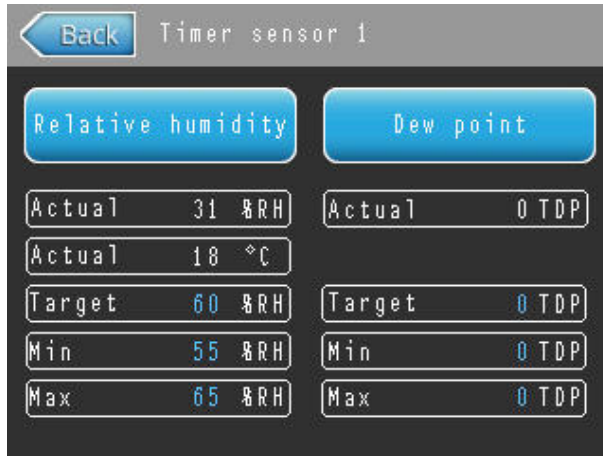

What you see:

Actual values measured by sensor 1 (measures both %RH, °C and actual dew point temperature).

Controlling RELATIVE HUMIDITY with the dehumidifier. Pressing the RELATIVE HUMIDITY checkbox at the top makes the dehumidifier control relative humidity as measured by the sensor (default setting).

The TARGET value can be changed by pressing the blue number. A keyboard then pops up where you can enter a desired value. The MAX and MIN values change automatically in ± 5 increments in relation to the entered target value. You should adjust the target value first, followed by the MAX and MIN values afterwards.

Threshold values (MIN and MAX) The MIN and MAX values can be changed in the same way, by pressing the blue numbers. The threshold values define the hysteresis for the RH On/Off, Energy, Quiet and Custom programs. When the actual %RH measured by the external sensor exceeds the MAX value (+1%RH), the dehumidifier starts. When the %RH measured by the external sensor is below the MIN value (-1%RH), the dehumidifier stops.

If the Capacity Control program is selected (Configuration-B only), only the TARGET and MIN values are shown. Here the target value is the desired target value that the dehumidifier must reach. The dehumidifier stops when the actual %RH is below the MIN value (-1%RH). If the dehumidifier must be kept operating at all times, the MIN value is set to (for example) 1%RH. If the relative humidity falls dramatically and the heater is not active for 1 minute, the regeneration air will shut down (when the temperature in the heating box falls below 60°C) and enable constant process air ventilation.

The MIN value defines when the dehumidifier is turned off in the Energy, Quiet and Custom programs (only for Configuration-C and Configuration-D). See page 54 for more information.

Controlling DEW POINT with the dehumidifier The MIN and MAX values can be changed in the same way, by pressing the blue numbers. Threshold values define the hysteresis for the RH On/Off, Energy, Quiet and Custom programs. When the actual dew point measured by the external sensor exceeds the MAX value (+1TDP), the dehumidifier starts. When the dew point measured by the external sensor is below the MIN value (-1TDP), the dehumidifier stops.

If the Capacity Control program is selected (Configuration-B only), only the TARGET and MIN values are shown. Here the target value is the desired target value that the dehumidifier must reach. The dehumidifier stops when the actual dew point is below the MIN value. If the dehumidifier must be kept operating at all times, the MIN value is set to (for example) -6 in dew point. If the dew point falls dramatically and the heater is not active for 1 minute, the regeneration air will shut down (when the temperature in the heating box falls below 60°C) and enable constant process air ventilation.

The MIN value defines when the dehumidifier is turned off in the Energy, Quiet and Custom programs (only for Configuration-C and Configuration-D). See page 54 for more information.

Controlling both RELATIVE HUMIDITY and DEW POINT with the dehumidifier If required, you can control the dehumidifier on the basis of both %RH and dew point measurements at the same time. In such cases, both checkboxes should be marked.

Return to main menu

Return to HUMIDITY menu

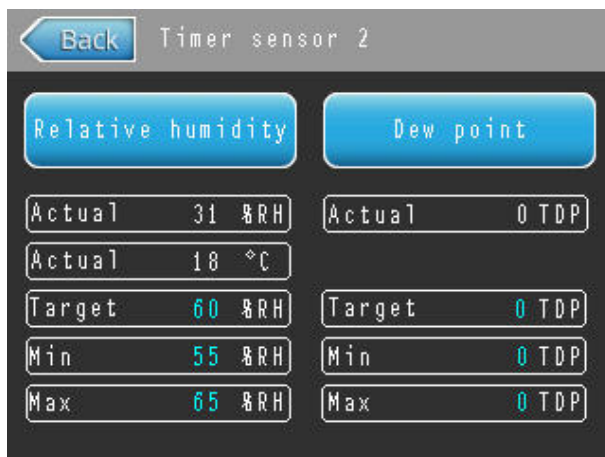
SET / TIMER / HUMIDITY / SENSOR2

What you see:

Actual values measured by sensor 2 (measures both %RH, °C and actual dew point temperature. Only available in Configuration-C and Configuration-D)

Controlling RELATIVE HUMIDITY with the dehumidifier. Pressing the RELATIVE HUMIDITY checkbox at the top makes the dehumidifier control relative humidity as measured by the sensor (default setting).

The TARGET value can be changed by pressing the blue number. A keyboard then pops up where you can enter a desired value. The MAX and MIN values change automatically in ± 5 increments in relation to the entered target value. You should adjust the target value first, followed by the MAX and MIN values afterwards.

Threshold values (MIN and MAX) The MIN and MAX values can be changed in the same way, by pressing the blue numbers. The threshold values define the hysteresis for RH On/Off, Energy, Quiet and Custom programs. When the actual %RH measured by the external sensor exceeds the MAX value (+1%RH), the dehumidifier starts. When the %RH measured by the external sensor is below the MIN value (-1%RH), the dehumidifier stops.

If the Capacity Control program is selected (Configuration-B only), only the TARGET and MIN values are shown. Here the target value is the desired target value that the dehumidifier must reach. The dehumidifier stops when the actual %RH is below the MIN value. If the dehumidifier must be kept operating at all times, the MIN value is set to (for example) 1%RH. If the relative humidity is falls dramatically and the heater is not active for 1 minute, the regeneration air will shut down (when the temperature in the heating box falls below 60°C) and enable constant process air ventilation.

The MIN value defines when the dehumidifier is turned off in the Energy, Quiet and Custom programs (only for Configuration-C and Configuration-D). See page 54 for more information.

Controlling DEW POINT with the dehumidifier The MIN and MAX values can be changed in the same way, by pressing the blue numbers. The threshold values define the hysteresis for the RH On/Off, Energy, Quiet and Custom programs. When the actual dew point measured by the external sensor exceeds the MAX value (+1TDP), the dehumidifier starts. When the dew point measured by the external sensor is below the MIN value (-1TDP), the dehumidifier stops.

If the Capacity Control program is selected (Configuration-B only), only the TARGET and MIN values are shown. Here the target value is the desired target value that the dehumidifier must reach. The dehumidifier stops when actual dew point is below the MIN value. If the dehumidifier must be kept operating at all times, the MIN value is set to (for example) -6 in dew point. If the dew point falls dramatically and the heater is not active for 1 minute, the regeneration air will shut down (when the temperature in the heating box falls below 60°C) and enable constant process air ventilation.

The MIN value defines when the dehumidifier is turned off in the Energy, Quiet and Custom programs (only for Configuration-C and Configuration-D). See page 54 for more information.

Controlling both RELATIVE HUMIDITY and DEW POINT with the dehumidifier If required, you can control the dehumidifier on the basis of both %RH and dew point measurements at the same time. In such cases, both checkboxes should be marked.

Return to main menu

Return to HUMIDITY menu

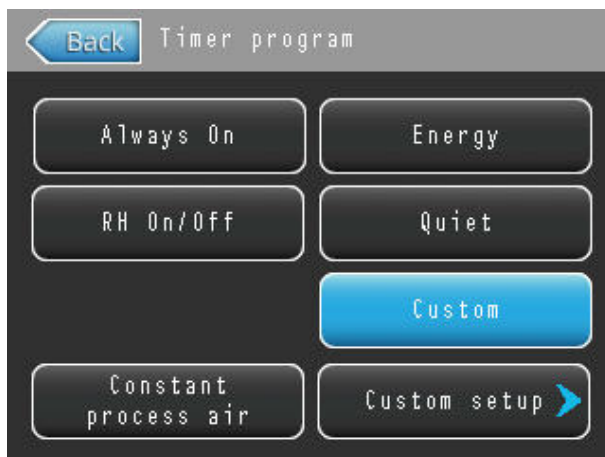
SET / TIMER / PROGRAM

What you see:

This only applies to the dehumidifier in timer mode.

ALWAYS ON The dehumidifier runs at full power all the time.

RH ON/OFF The dehumidifier is controlled by an external sensor. When the values measured by this sensor are below the MIN value you have set, the dehumidifier is turned off. When the values measured by this sensor are above the MAX value you have set, the dehumidifier is turned on, and running at full power. See page 49 and 51 for more details about targets and thresholds.

CONSTANT PROCESS AIR The main purpose is to enable air circulation even though dehumidification is not required. The CONSTANT PROCESS AIR selection is not a standalone program and is only operating in collaboration with another program selection. If RH ON/OFF program is chosen and the dehumidifier stops operating due to achieved humidity levels – the process fan continue to operate when the CONSTANT PROCESS AIR selection is enabled.

CAPACITY CONTROL (Configuration-B only). The focus here is on removing unwanted humidity, so the fans run all the time if the MIN value is set to (for example) 1%RH. When the values measured by this sensor are below the MIN value you have set, the dehumidifier is turned off. The temperature increases slowly in order to dehumidify in accordance with the capacity required. If the target value is lower than the actual %RH as measured by the external sensor, the dehumidifier's heating capacity will be fully activated within approximately 10–15 minutes (100% heating capacity). When the actual %RH is within the target value, the heating capacity is automatically adjusted to meet requirements. For detailed instructions about how to setup target values in the capacity control program, see page 49.

ENERGY (Configuration-C only). In addition to removing unwanted humidity, the focus here is on removing such humidity in a more energy-efficient manner. When turned on, the speed of the rotor and the level of heat are adjusted to meet requirements and to save energy.

The dehumidifier is turned off when the values measured by the sensor(s) are below the threshold MIN value you have set. See page 49 and 51 for more details.

ENERGY+ (Configuration-D only). The focus here is on removing unwanted humidity and keeping overall energy consumption to a minimum. In the ENERGY program for Configuration-D, the flow of air, the level of heat and the rotation of the humidity-absorbing rotor are all controlled by measurements made by high-precision internal sensors.

The dehumidifier is turned off when the values measured by the sensor(s) are below the threshold MIN value you have set. See page 49 and 51 for more details.

QUIET (Configuration-C and Configuration-D only). The focus here is on making sure the dehumidifier runs as quietly as possible. The dehumidifier is only turned on when the values measured by external sensor are above the target you have set.

In this configuration, all the air flows are reduced as much as possible, in order to keep noise levels to a minimum.

The dehumidifier is turned off when the values measured by the sensor(s) are below the threshold MIN value you have set. See page 49 and 51 for more details.

CUSTOM SETUP (Configuration-C and Configuration-D only). In this configuration, you can adjust all the values individually, within predefined limits. See page 58 for more details.

The dehumidifier is turned off when the values measured by the sensor(s) are below the threshold MIN value you have set. See page 49 and 51 for more details.

Return to main menu

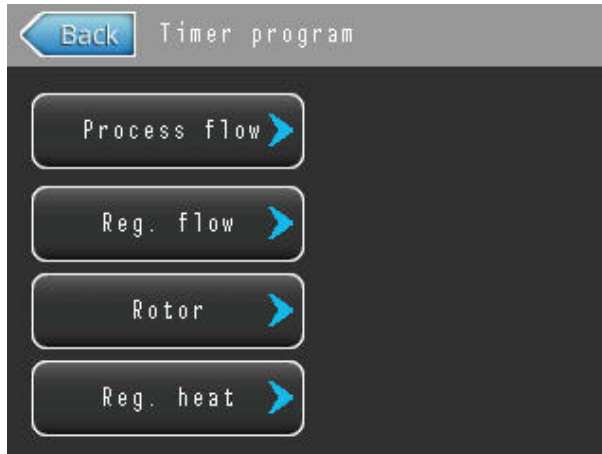
SET / TIMER / TIMER PROGRAM

What you see:

Adjustment of process flow in timer mode (Configuration-C and Configuration-D only)

Adjustment of regeneration air flow in timer mode

Adjustment of rotor speed in timer mode (Configuration-C and Configuration-D only)

Adjustment of levels of heat in regeneration air flow in timer mode

Return to main menu

Return to TIMER menu

**NOTE**

You should only use the CUSTOM menu to make changes to the operating settings if you are familiar with the effect of the different parameters and know what you are doing.

If the settings are incorrect or ill-advised, this can have substantial effects on your installations or processes, and may even damage the dehumidifier.

Condair cannot take responsibility for any changes you make in the standard programs, or for the results of any such changes.

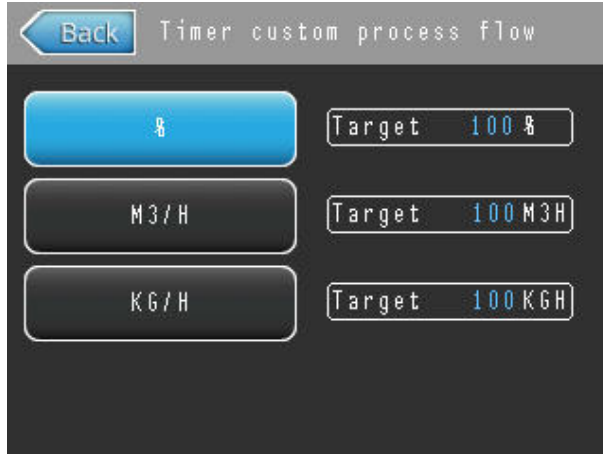
SET / TIMER / TIMER PROGRAM / CUSTOM / PROCESS FLOW

What you see:

% in relation to maximum fan speed (Configuration-C and Configuration-D only)

m³/hour (Configuration-C and Configuration-D only)

kg/hour (Configuration-C and Configuration-D only)

Return to main menu

To **TIMER CUSTOM** menu

The setting you have selected appears in blue.

The values in this setting remain constant while the dehumidifier is running, but the other values can change.

You change the values by pressing on the blue number, and you change the function by pressing anywhere else on the button.

The dehumidifier is turned off when the values measured by the sensor(s) are below the threshold MIN value you have set. See page 82 and 84 for more details.

**NOTE**

You should only change the process air flow if you are familiar with the effect of the different parameters and know what you are doing.

If the settings are incorrect or ill-advised, this can have substantial effects on your installations or processes, and may even damage the dehumidifier.

Condair cannot take responsibility for any changes you make in the standard programs, or for the results of any such changes.

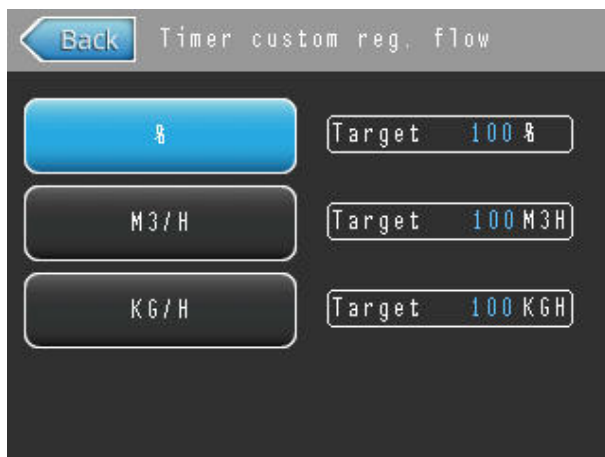
SET / TIMER / TIMER PROGRAM / CUSTOM / REGENERATION FLOW

What you see:

% in relation to maximum fan speed (Configuration-C and Configuration-D only)

m³/hour (Configuration-C and Configuration-D only) (based on normal m³ [20°C])

kg/hour (Configuration-C and Configuration-D only)

Return to main menu

To **TIMER CUSTOM** menu

The setting you have selected appears in blue.

The values in this setting remain constant while the dehumidifier is running, but the other values can change.

You change the values by pressing on the blue number, and you change the function by pressing anywhere else on the button.

The dehumidifier is turned off when the values measured by the sensor(s) are below the threshold MIN value you have set. See page 82 and 84 for more details.

**NOTE**

You should only change the regeneration air flow if you are familiar with the effect of the different parameters and know what you are doing.

If the settings are incorrect or ill-advised, this can have substantial effects on your installations or processes, and may even damage the dehumidifier.

Condair cannot take responsibility for any changes you make in the standard programs, or for the results of any such changes.

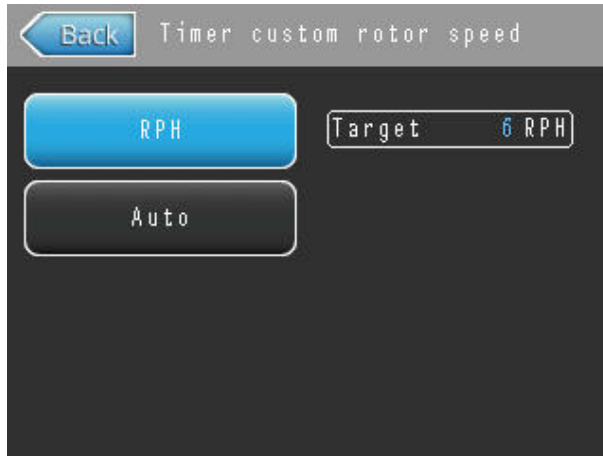
SET / TIMER / TIMER PROGRAM / CUSTOM / ROTOR SPEED

What you see:

RPH – this is where you select rotor speed (Configuration-C and Configuration-D only), by pressing the blue number, and entering the new value

AUTO – automatically calculates the ideal rotor speed (rph)

Return to main menu

To **TIMER CUSTOM** menu

The dehumidifier is turned off when the values measured by the sensor(s) are below the threshold MIN value you have set. See page 82 and 84 for more details.

**NOTE**

You should only change rotor speed if you are familiar with the effect of the different parameters and know what you are doing.

If the settings are incorrect or ill-advised, this can have substantial effects on your installations or processes, and may even damage the dehumidifier.

Condair cannot take responsibility for any changes you make in the standard programs, or for the results of any such changes.

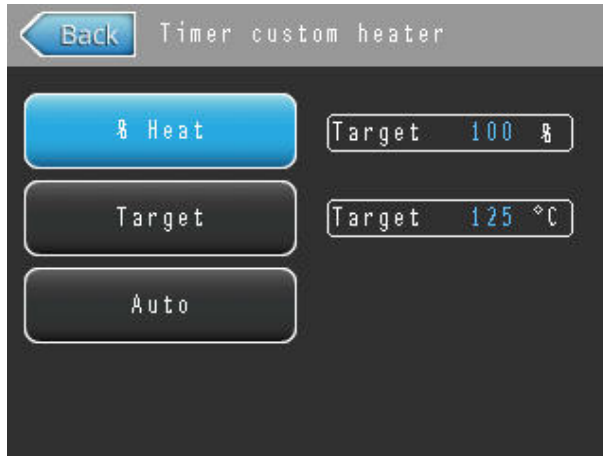
SET / TIMER / TIMER PROGRAM / CUSTOM / HEATER

What you see:

% HEAT Select heat setting as % of maximum possible heat effect.

TARGET Select desired temperature (fixed temperature). NB you may not be able to achieve the desired temperature, because this depends on air conditions outside. However, the dehumidifier will use this value as a target that it will attempt to achieve.

AUTO Automatically calculates the ideal level of heat in relation to the setting for regeneration air flow.

Return to main menu

To **TIMER CUSTOM** menu

The dehumidifier is turned off when the values measured by the sensor(s) are below the threshold MIN value you have set. See page 82 and 84 for more details.

NOTE

You should only change the heater temperature if you are familiar with the effect of the different parameters and know what you are doing.

If the settings are incorrect or ill-advised, this can have substantial effects on your installations or processes, and may even damage the dehumidifier.

Condair cannot take responsibility for any changes you make in the standard programs, or for the results of any such changes.



SET / LANGUAGE

What you see:

These are the languages you can choose the interface for this Condair dehumidifier.

Choose the language you prefer to use to operate this system.

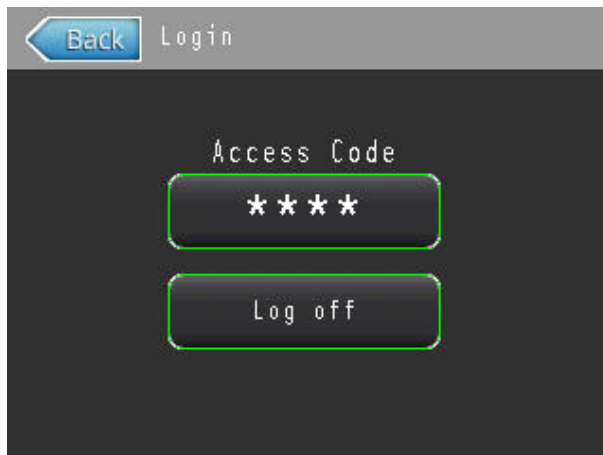
SET / LOGIN

What you see:

This is where you enter your operator code (1234), and press ENTER. You are now logged in for 10 minutes, so that you can set operating targets and other settings.

LOG OFF – this is where you log off.

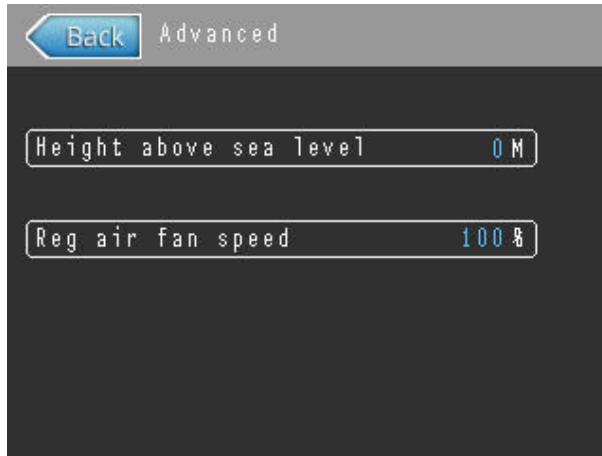
SET / ADVANCED

What you see:

HEIGHT ABOVE SEA LEVEL (Configuration-C and Configuration-D only). This is used to ensure correct calculation of air densities in different programs.

REGENERATION AIR FAN (Configuration-B only). This is where you set the regeneration air fan.

These settings are only adjusted once – during the installation process.

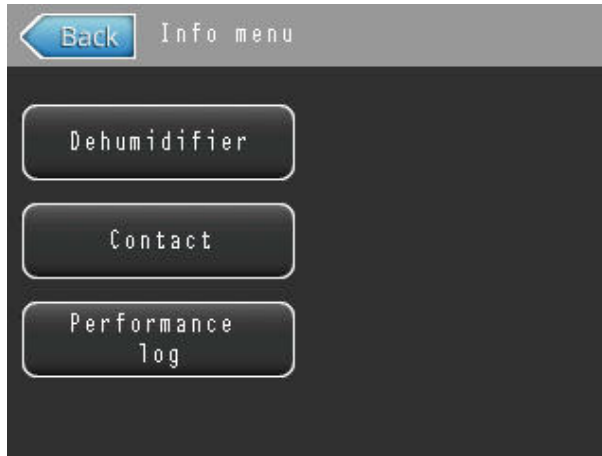
INFO menu

What you see:

DEHUMIDIFIER – information about your Condair dehumidifier, including its service history

CONTACT – information about where/how to contact Condair or a Condair dealer

PERFORMANCE LOG – the performance log for your Condair dehumidifier

Return to main menu

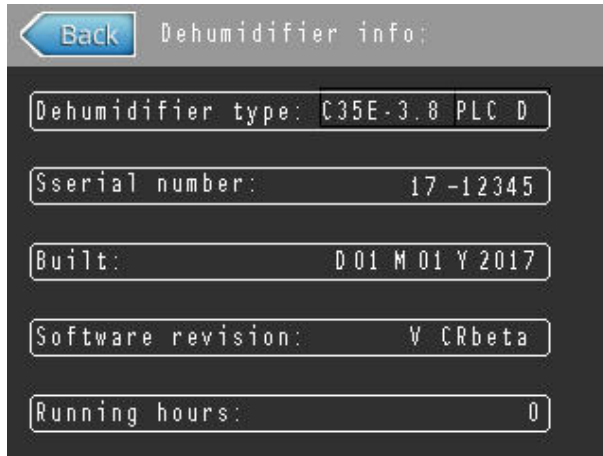
INFO / DEHUMIDIFIER

What you see:

DEHUMIDIFIER TYPE – defines the type and configuration of the dehumidifier

SERIAL NUMBER – dehumidifier serial number

BUILD – date of build

SOFTWARE REVISION – which software revision is installed in the PLC-controller

RUNNING HOURS – total running hours

Return to main menu

To **INFO** menu

INFO / SERVICE HISTORY

What you see:

SERVICE HISTORY – List of service performed on dehumidifier. It is up to you and your company whether you wish to enter relevant service information here.

Press the empty space to enter relevant information.

Return to main menu

To **INFO** menu

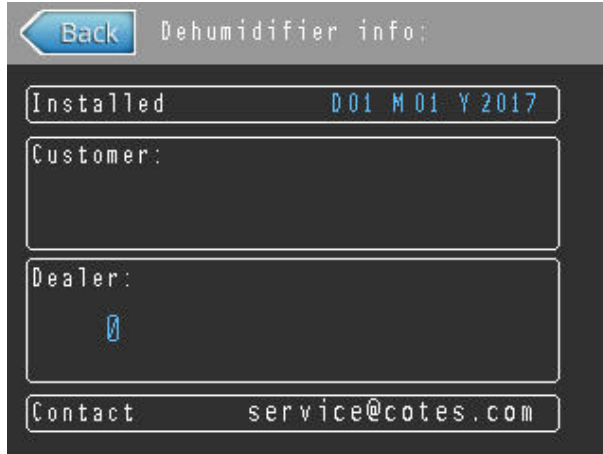
INFO / CONTACT

The screenshot shows a terminal-style interface for 'Dehumidifier info'. At the top left is a blue 'Back' button. The title 'Dehumidifier info:' is displayed. Below are four data fields:

Installed	D 01 M 01 Y 2017
Customer:	
Dealer:	0
Contact	service@cotes.com

What you see:

INSTALLED – date of installation

CUSTOMER – who benefits from using the dehumidifier

DEALER – who sold the dehumidifier to the customer. 0 = empty space where you can enter data manually. Press the blue 0 (zero) and enter 1 to 17. Each Condair dealer has its own pre-defined data incorporated into the PLC controller.

CONTACT – how to get in contact with Condair

Return to main menu

To **INFO** menu

INFO / PERFORMANCE LOG

What you see:

DATE – the date the data was logged

TIME – the time the data was logged

RH1 – the actual %RH measured by SENSOR 1

DP1 – the actual dew point measured by SENSOR 1

RH2 – the actual %RH measured by SENSOR 2

DP2 – the actual dew point measured by SENSOR 2

ARROW DOWN – browsing downwards in performance log

ARROW UP – browsing upwards in performance log

Return to main menu

To **INFO** menu

HOW TO OPERATE THE DA 65E / DA 65D CONFIGURATION-A

The DA 65E / DA 65D / DA 65C Configuration-A is designed for maximum dehumidification, and the standard setting is that it is kept running at all times. This configuration is kept as simple as possible, which is why there is no dehumidification management installed.

STARTING AND STOPPING THE DEHUMIDIFIER

You switch the dehumidifier on at the main switch.

After a short period, the dehumidifier is ready to operate. When the main switch is on, the integrated LED strip displays a single green diode at the lower end of the strip.

To turn the dehumidifier on, press the button on the left of the main switch. Press the button again to turn the dehumidifier off.

When the dehumidifier is operating, the entire LED strip is green.

HOUR COUNTER

The mechanical hour counter is located on the front of the machine.

ALARM

The LED strip in the front of the panel turns red if an alarm occurs.

The Configuration-A cannot provide information about what type of alarm has been triggered. An alarm can be triggered by (for example) an overheating alarm or by malfunctions in gear, the process air fan or the regeneration air fan. Furthermore, a switch or relay may have been deactivated and needs to be activated again.

EXTERNAL HUMIDITY MANAGEMENT

You can purchase an external humidity hygostat to manage when the dehumidifier is operating or not. Contact Condair or your Condair dealer for more information.

SECTION 6 / SERVICE AND REPAIR

HOW TO SERVICE AND REPAIR THIS DEHUMIDIFIER

Service and maintenance work on this dehumidifier

Condair designs its dehumidifier units so that they are as robust as possible, and only need a minimum of service and maintenance.

None of the components require lubrication or adjustment.

The only maintenance work you need to do is listed below.

Once a month

- Check or replace the filters for incoming air and regeneration air. For Configuration-B, Configuration-C and Configuration-D, the filter guard will automatically provide a warning if there are problems.
- Check that the fans are operating (by listening to check whether they are turning).

Once a year

We also recommend the following annual checks.

- Check the service indication menu in the PLC controller. Are the working hours of any component inside near their time-to-change limit? If so, replace. See time-to-change limits below:
 - Process air filter. Depends on the working environment. Specified for 8,700 hours under normal conditions.
 - Regeneration air filter. Depends on the working environment. Specified for 8,700 hours under normal conditions.
 - Air filter for electrical box. Depends on the working environment. Specified for 8,700 hours under normal conditions.
 - Process air fan: 40,000 hours
 - Regeneration air fan: 30,000 hours
 - Motor and gear for rotor: 30,000 hours
 - Heaters: 40,000 hours
 - Filter guard (if installed): 40,000 hours
 - Manometer (if installed): 40,000 hours
 - Rotor, including gaskets: 60,000 hours
 - Electrical board including PLC controller: 60,000 hours

- External humidity sensor should be calibrated or replaced (with recycled instruments)
- Internal humidity sensor (only Configuration-D) should be replaced (with recycled instruments)
- Check the wear on the rotor gaskets, especially the gasket placed on the circumference of the rotor. The red side of the gasket is made of Teflon®, and this coating must be intact over its entire surface.
- Check the inside of the cabinet for any signs of dirt or corrosion. Check that the drive belt for the rotor is still tight and that no parts of it are too worn or close to the breaking point.
- Check that the insulation on all electrical cables is intact, with no mechanical or heat damage.
- Check that the insulation on the electric heater(s) is intact.
- Check that all cables inside the electrical box are properly attached, all miniature circuit breakers (MCBs) are switched on and all components are intact.
- Test that all electric components are working as intended – for example by following the instructions in the “Commissioning” section of this handbook.

Service/repair work on this dehumidifier

Safety instructions

Before opening the dehumidifier, make sure that the electric current is switched off at the mains before you open the cover of the electrical box or the covers for the electric heater, process air fan and rotor.

The 10Q1 safety switch should also be switched off.

You should never just turn off the power to the dehumidifier while it is running. The correct procedure is to press STOP DA 65 DEHUMIDIFIER (Configuration-A; press the operating button), after which the machine runs a cooling cycle before the regeneration air fan stops. Turning off the dehumidifier properly prevents any over-heating.



WARNING

Make sure that electric current is switched off at the mains before you open the cover of the electrical box or the covers for the electric heater, process air fan and rotor

The 10Q1 safety switch should also be switched off.

Easy access for quick service

The electrical switchboard (contacts, fuse breakers, thermal relays, etc.) is placed in the electrical box in the top of the dehumidifier cabinet, directly under the top cover, to make them easy to get to.

All other electrical components (fan motors, gear motor, heating elements, etc.) are easy to access when the service door for these parts is opened.

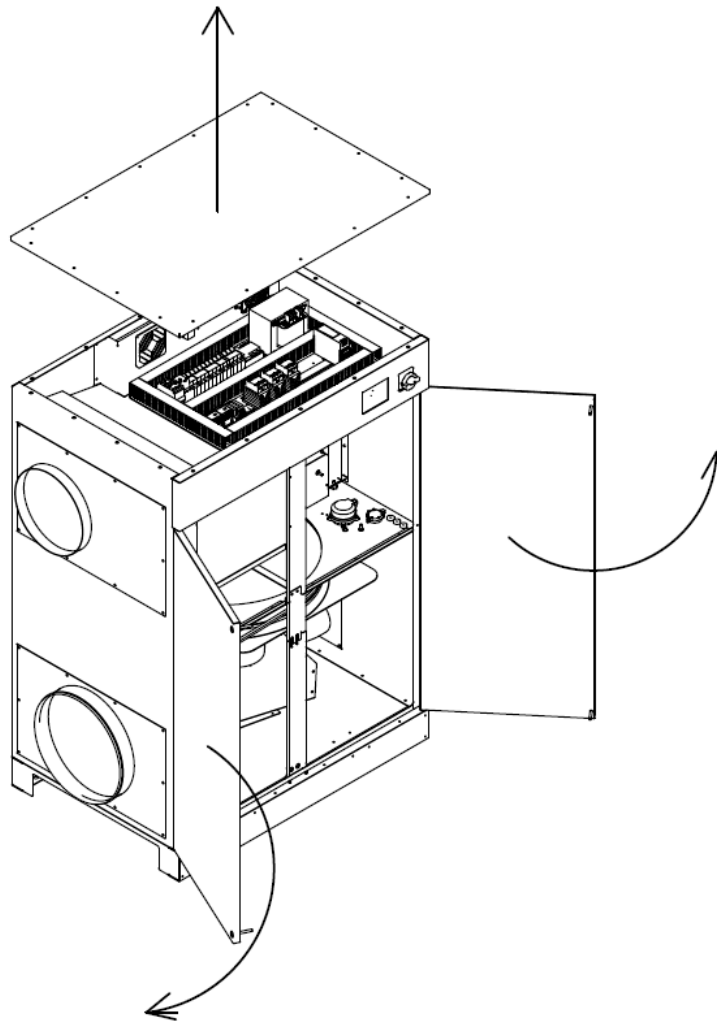
**Connecting 230V motors**

All DA 65E / DA 65D / DA 65C dehumidifiers are fitted with 230V AC electric motors for the fans. This means it doesn't matter how the plus/minus cables are connected.

Nevertheless, the gear motor must be connected correctly and you must check that the rotor turns clockwise when connected.

Replacing filters

Process air filter; 130372

Regeneration air filter; 130373

Use only high-temperature resistance filters for the regeneration air flow.

(Except if special filters are specified).

The following is standard procedure for replacing the filters:

- Open front door
- Loosen the finger screws on the filter doors
- Replace the filters

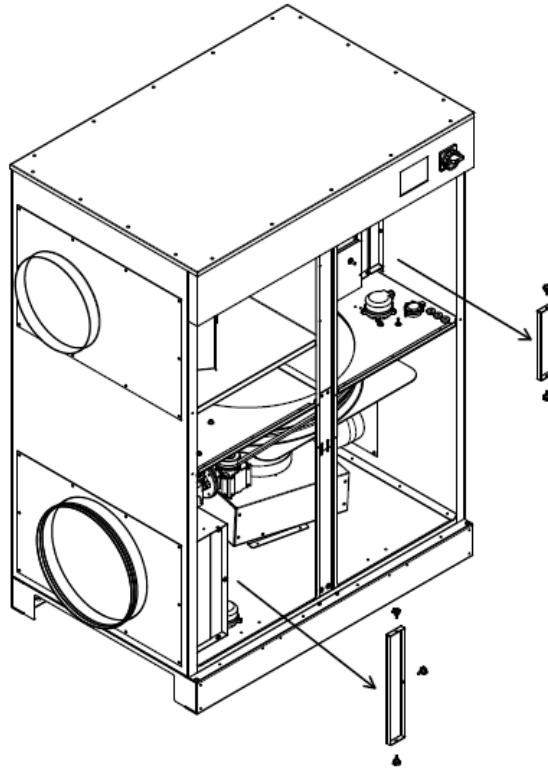

Replacing fans

Large process air fan: RH31C;	801670	Large regeneration air fan: RH28M;	620710
Medium process air fan: RH25C;	801699	Medium regeneration air fan: RH25C;	620527
Small process air fan: RH25C;	801667	Small regeneration air fan: RH19V;	614371

The following is standard procedure for replacing the process air fan;

- Open front door
- Disconnect cables for process air fan
- Remove the screws on the fan bracket
- Remove the screws on the fan
- Remove the fan bracket
- Remove the fan
- Replace the process air fan

The following is standard procedure for replacing the regeneration air fan:

- Disconnect cables for regeneration air fan
- Dismount screw clamp fastened to the regeneration air fan box
- Remove the regeneration air fan box
- Insert a replacement regeneration air fan box, or remove the screws on the regeneration air fan box and replace the regeneration air fan

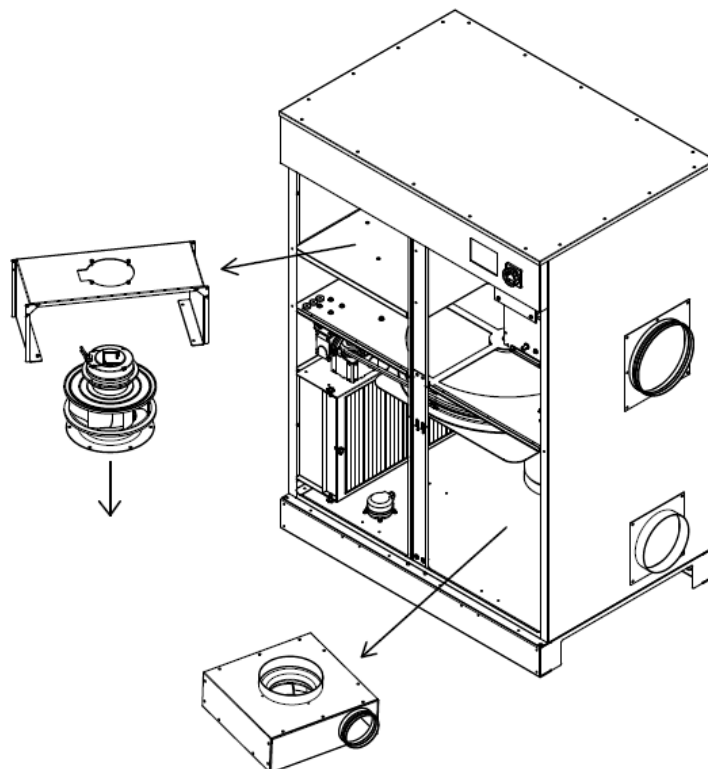

Replacing PLC

PLC; 140621

The following is standard procedure for replacing the PLC unit.

- Remove the top cover
- Disconnect cables for the PLC
- Remove the screws for the PLC bracket
- Replace the PLC

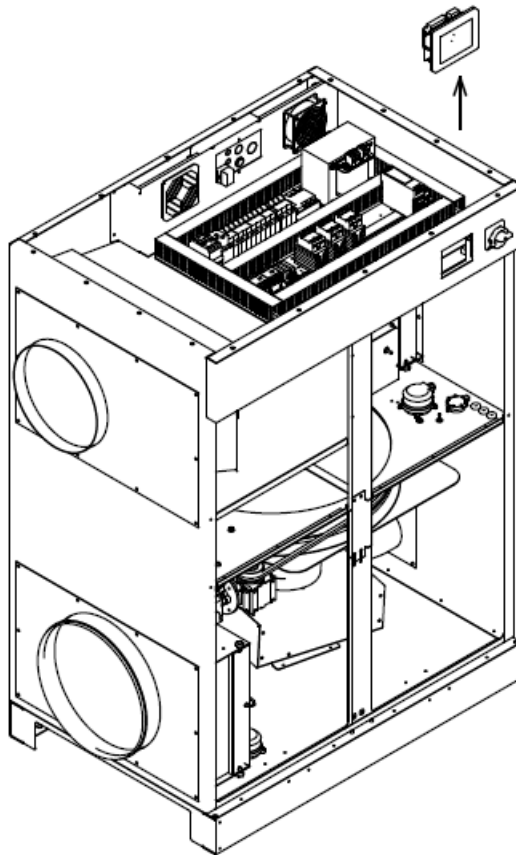

Replacing electrical board

400V 24A electrical board;	620519
400V 24A electrical board Basic;	620750
400V 50A electrical board;	620754
400V 50A electrical board Basic;	620755

The following is standard procedure for replacing an electrical board

- Open the top cover
- Disconnect all cables and sensors connected to the electrical board
- Remove the screws fastening the electrical board to the cabinet
- Replace the electrical board

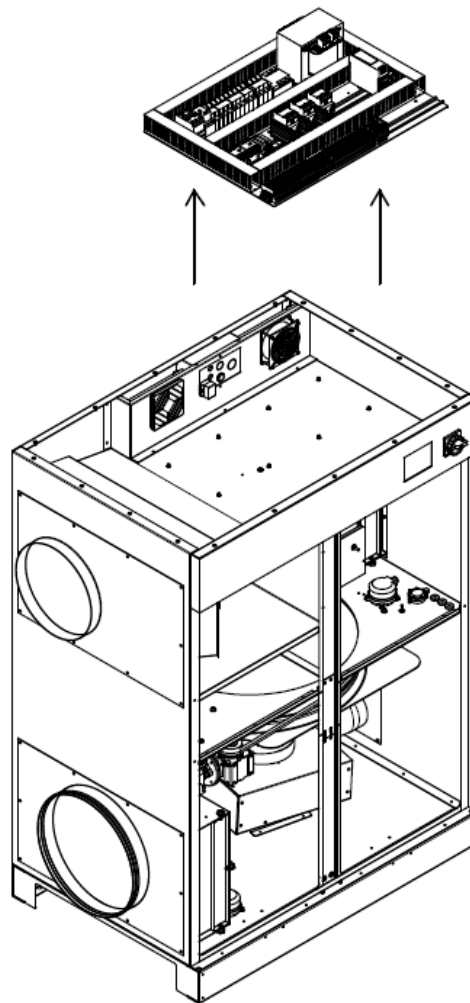

Replacing gear motor

Remove the drive belt from the pulley, and then remove the gear motor after disconnecting all electrical connections. You should then fit a replacement gear motor.

When re-starting the unit, check that the rotor is moving. If not, check connection on the motor.

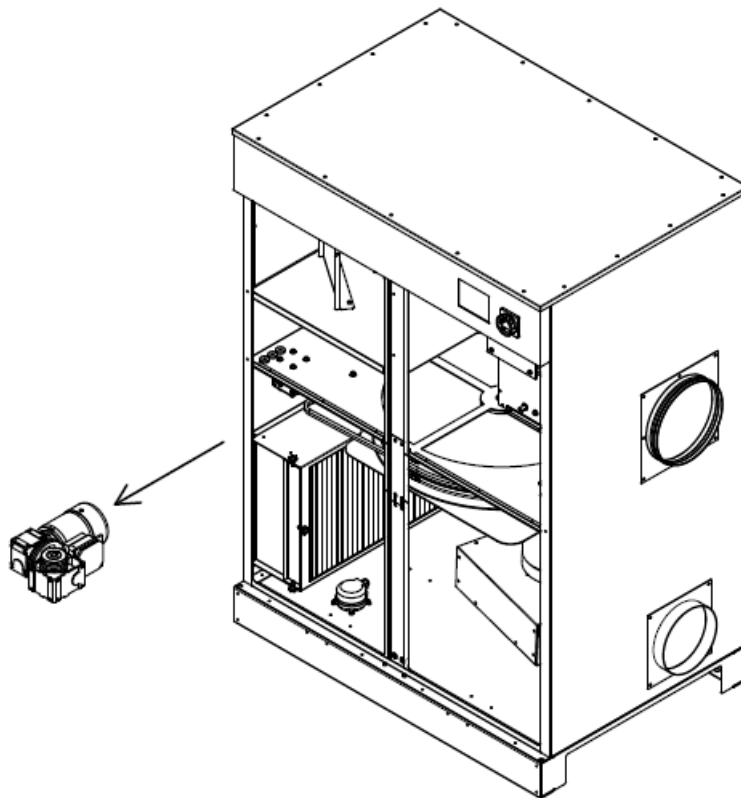

Replacing electric heaters

All electric heaters are mounted in the front of the heater section of the dehumidifier.

To replace these units, disconnect the wiring and unscrew the plate. You can then withdraw the plate and heaters from the heating section.

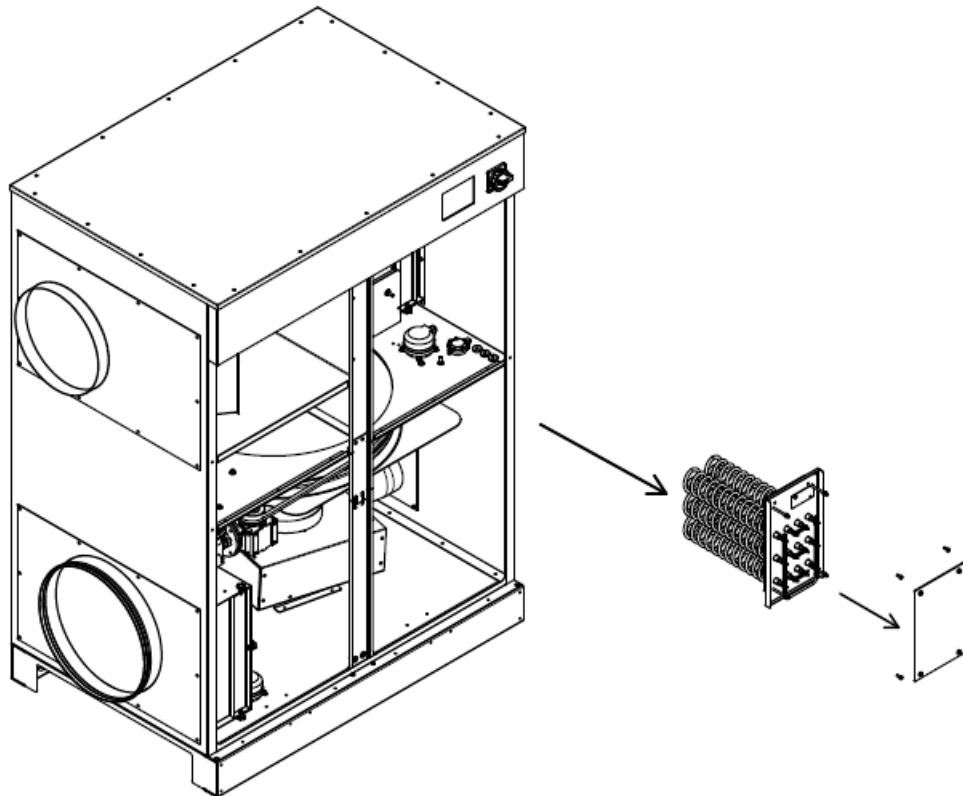

Replacing rotor, rotor gaskets and shaft

You do not need to remove the rotor to replace the rotor gaskets. You simply place the new gasket on the rotor and fix it in place with the three-part expansion ring. You then turn the rotor, which presses the gasket against the departing plates until only half of the gasket is on the rotor. The expansion ring then fastens.

The following is standard procedure for replacing rotor gaskets.

- Open door at the front of the cabinet
- Remove the drive belt from the pulley
- Remove the rotor gaskets
- Mount new rotor gaskets

You *can* remove the rotor and mount new gaskets on it, but it is much easier to mount new gaskets *without* removing the rotor.

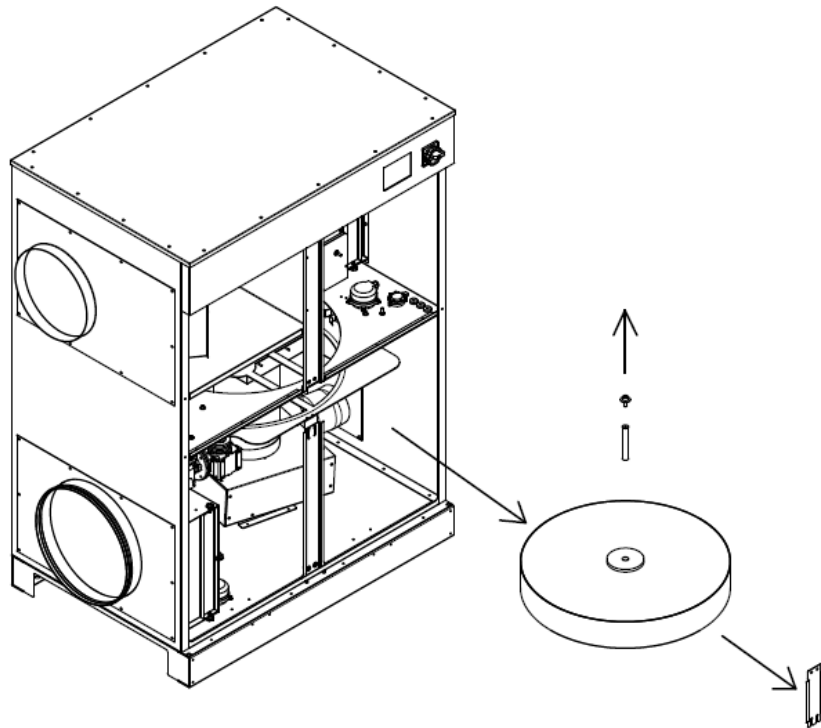

The following is standard procedure for replacing the rotor.

- Open door at the front of the cabinet
- Remove the middle support
- Remove the drive belt from the pulley
- Remove the rotor gaskets
- Remove the screws for the rotor shaft
- Remove the screws for the lower divider and spacers in-between the dividers

Carefully slide out the rotor (including the Teflon® disc and rotor shaft) before the rotor shaft can be dismounted at the front.

Troubleshooting

Problem	Cause	Action
The unit (or parts of it) will not start after a power surge/an electrical short circuit	One or more fuse breakers have been triggered	Turn all fuse breakers on
The air is not as dry as expected	The rotor is not turning The regeneration air temperature is lower than expected The regeneration air flow is too low	If the drive belt is intact, change the gear motor Check that the regeneration air flow is not too high Check that all heating elements are functioning Check that the regeneration air filter is not clogged
The regeneration air temperature has large variations	The regeneration air flow is too low	Check that the regeneration air filter is not clogged
The Alarm menu displays "Overheating Alarm"	The 252ST2 safety switch has been triggered and must be deactivated	Deactivate the safety switch by pressing the small green button. The switch is in the cable connection box in the back of the dehumidifier Check whether the regeneration air flow is too low Check whether the filters should be changed
The Alarm menu displays "Process Air Fan"	One or more fuse breakers have been triggered Wires to or from the fan or fuse breakers have become disconnected Wire connections inside the RH25C/RH31C process fan have become disconnected The fan is broken	Turn all fuse breakers on Check that all the wire connections comply with the electrical diagram If all the wire connections are connected correctly, replace the fan

<p>The Alarm menu displays "Reg. Air Fan"</p>	<p>One or more fuse breakers have been triggered</p> <p>Wires to or from the fan or fuse breakers have become disconnected</p> <p>The fan is broken</p>	<p>Turn all fuse breakers on</p> <p>Check that all the wire connections comply with the electrical diagram</p> <p>If all wire connections are connected correctly, replace the fan</p>
---	---	--

If you have any queries or questions, please contact your Condair dealer.

SECTION 7 / FORMALITIES AND GENERAL/LEGAL INFO

WARRANTIES

Warranty conditions

The Condair factory warranty is only valid if a documented programme of service and preventive maintenance has been carried out.

Maintenance must have been carried out at intervals of six months or less. Documentation for this must be in the form of a written log/journal, with attested entries.

All spare parts must have been purchased from Condair or an authorised Condair dealer.

LEGAL NOTICES

Terms

The information contained in this publication and the products and equipment described herein are subject to change at any time without prior notice.

Condair Group AG has no obligation to inform buyers of the products and equipment of such subsequent changes.

This publication may contain misprints. Condair Group AG is not liable for errors or omissions in this publication or for incidental or consequential damages in connection with the furnishing of or the use of this publication.

Condair Group AG is not liable for any loss or damages, including consequential damages caused by disregard of any advice or warnings in relation to safety in this publication.

This publication cannot be deemed to contain any express or implied warranties of any kind concerning the construction or the suitability of the products described or the fitness of the products for any particular purpose.

This publication is subject to the provisions and requirements laid down in Swiss law.

Copyright

All copyright to this publication belongs to Condair Group AG.

All rights reserved. You are not allowed to photocopy, reproduce, adapt, modify, translate, display or transfer any part of this publication to any other media, without explicit prior written permission from Condair Group AG.

EU DECLARATION OF CONFORMITY

Condair Group AG
Talstrasse 35-37
CH-8808 Pfäffikon SZ
Switzerland
www.condair.com



Declares at its own liability that the following models of Condair adsorption dehumidifiers:

DA 30E, DA 35E, DA 35D, DA 65E, DA 65D

CE marking: Are covered by this declaration complying with the following directives:

Machinery Directive 2006/42/EC

Ecodesign 327/2011 directive 2009/125/EF as regards the eco-design fans driven by motors with input power and 125W to 500kW.

EMC Directive 2014/30/EU

RoHS 2011/65/EC.

and are manufactured in compliance with the following harmonised standards:

EN12100:2010

Safety of machinery – general principles for design - Risk assessment and risk reduction

EN 60204-1:2006+A1:2009

Safety of machinery – electrical equipment

Part 1: General requirements

EN 61000-6-3:2007/A1:2011/AC:2012

Electromagnetic compatibility (EMC) -- Part 6-3: Generic standards - Emission standard for industrial environments commercial and light-industrial environments

EN 61000-6-2:2005

Electromagnetic compatibility (EMC) -- Part 6-2: Generic standards - Immunity for industrial environments

EN 61000-3-2:2006+A1:2009+A2:2009

Electromagnetic compatibility (EMC) -- Part 3-2: Limits – Limits for harmonic current emissions (equipment input current ≤ 16 A per phase)

EN 61000-3-3:2013

Electromagnetic compatibility (EMC) — Part 3-3: Limits — Limits for harmonic current emissions (equipment input current ≤ 16 A per phase)

Pfäffikon CH, 2.2.2017.2016



Robert Merki

HOW TO UPDATE AND IMPROVE THIS CONDAIR DEHUMIDIFIER

Energy recovery

An energy recovery system can be placed beside the dehumidifier to reduce the amount of energy needed for heating the regeneration air.

Extra insulation

The doors of the Condair dehumidifier can be insulated to ensure that the sound pressure level of the unit is reduced and to ensure that all energy (both cooling and heating) is kept inside the unit.

Additional cooling/heating coil

A pre-cooling coil can increase the amount of moisture removed, especially when very dry air is needed.

Additional post cooling/heating

A post cooler/heater unit can be attached to the dehumidifier to control the temperature downstream from the dehumidifier.

Additional/better filters

If cleaner air is needed, it is possible to replace the fitted filter with a different filter featuring other specifications. If an additional filter is required, please contact Condair expert and find out how the unit can be changed for this to be done.

Next step

Please contact Condair or a Condair dealer to find the best solution.

WHO TO CONTACT

Help when and where you need it

Contact Condair in Switzerland or your local dealer:

Condair contact information:

Condair Group AG
Talstrasse 35-37
CH-8808 Pfäffikon SZ
Switzerland
+41 55 416 61 11
info@condair.com
www.condair.com

CONSULTING, SALES AND SERVICE:



CH94/0002.00

Condair Group AG
Talstrasse 35-37, CH-8808 Pfäffikon (SZ)
Phone +41 55 416 61 11, Fax +41 55 416 62 62
info@condair.com, www.condair.com

The Condair logo features a stylized graphic of three wavy lines to the left of the word 'condair' in a bold, lowercase, sans-serif typeface.